

# Modelling Aquatic Ecosystems

## Course 701-0426-00

Nele Schuwirth

ETH Zürich, Department of Environmental Systems Sciences  
Eawag, Swiss Federal Institute of Aquatic Science and Technology

1. Introduction, principles of modelling environmental systems, mass balance in a mixed reactor, process table notation, simple lake plankton model  
Exercise: R, ecosim-package, simple lake plankton model  
Exercise: lake phytoplankton-zooplankton model
2. Process stoichiometry Exercises: analytical solution, calculation with stoichcalc
3. Biological processes in lakes
4. Physical processes in lakes, mass balance in multi-box and continuous systems Exercise: structured, biogeochemical-ecological lake model  
Assignments: build your own model by implementing model extensions
5. Physical processes in rivers, bacterial growth, river model for benthic populations Exercise: river model for benthic populations, nutrients and oxygen
6. Stochasticity, uncertainty, parameter estimation  
Exercise: uncertainty, stochasticity
7. Existing models and applications in research and practice, examples and case studies, preparation of the oral exam, feedback

- Review exercise 4 (**chapter 11.4**)
- Learn how to model the growth of bacteria (**chapter 8.8**)
- Know the most important transport and mixing processes in rivers and how to implement them in a model (**chapter 6.1.2**)
- (Preview River Models (**chapter 11.5-11.6**))

**State variables:**

ALG, ZOO,

$\text{HPO}_4^{2-}$ ,  $\text{NH}_4^+$ ,  $\text{NO}_3^-$ ,  $\text{O}_2$ ,

POM: inert/degradable,  
suspended/sedimented

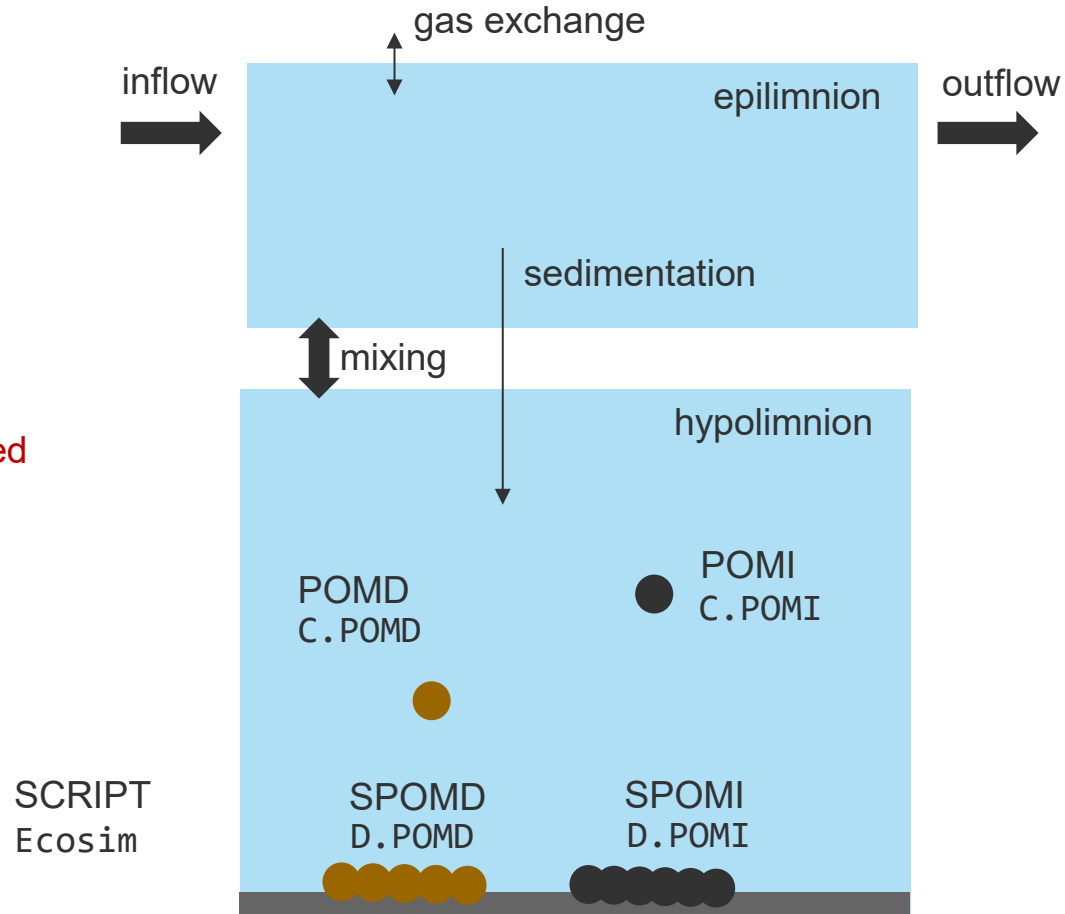

## State variables:

ALG, ZOO,

$\text{HPO}_4^{2-}$ ,  $\text{NH}_4^+$ ,  $\text{NO}_3^-$ ,  $\text{O}_2$ ,

POM: inert/degradable,  
suspended/sedimented

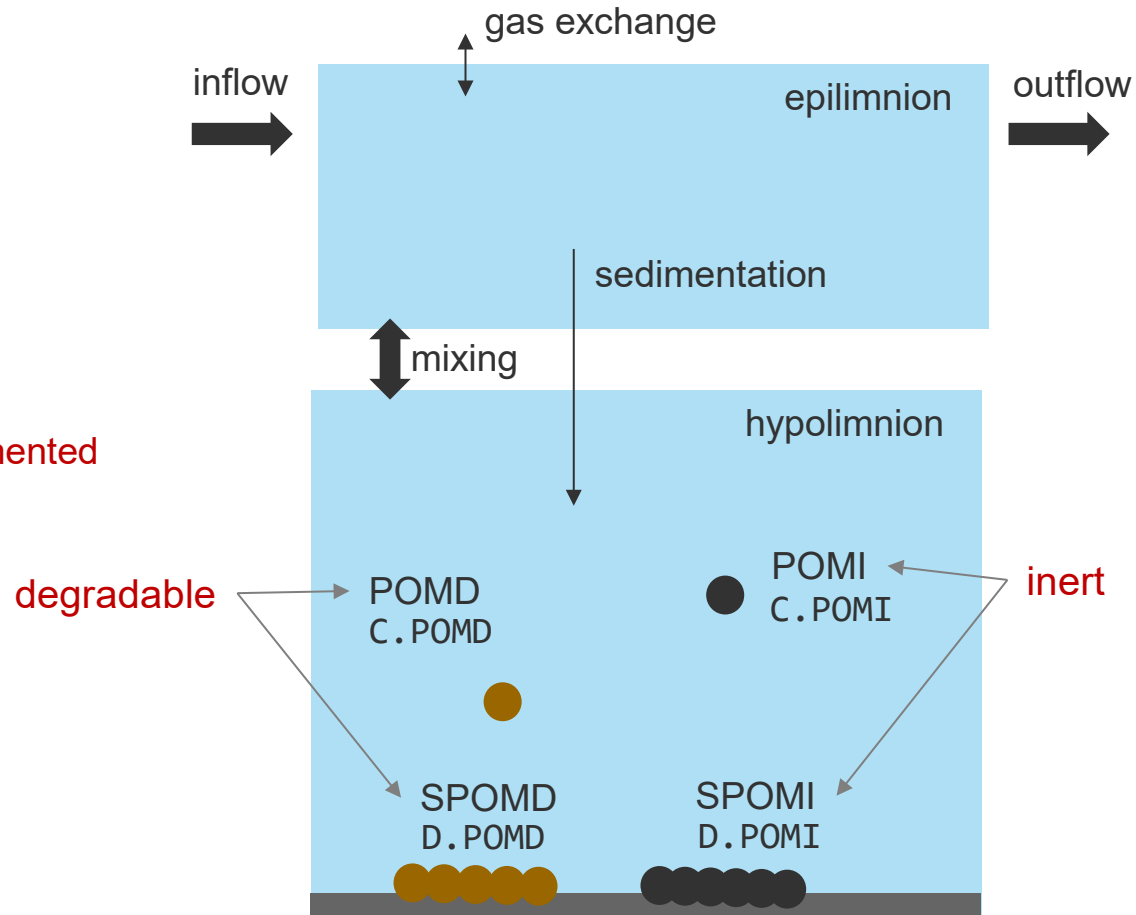

**State variables:**

ALG, ZOO,

$\text{HPO}_4^{2-}$ ,  $\text{NH}_4^+$ ,  $\text{NO}_3^-$ ,  $\text{O}_2$ ,

POM: inert/degradable,  
suspended/sedimented

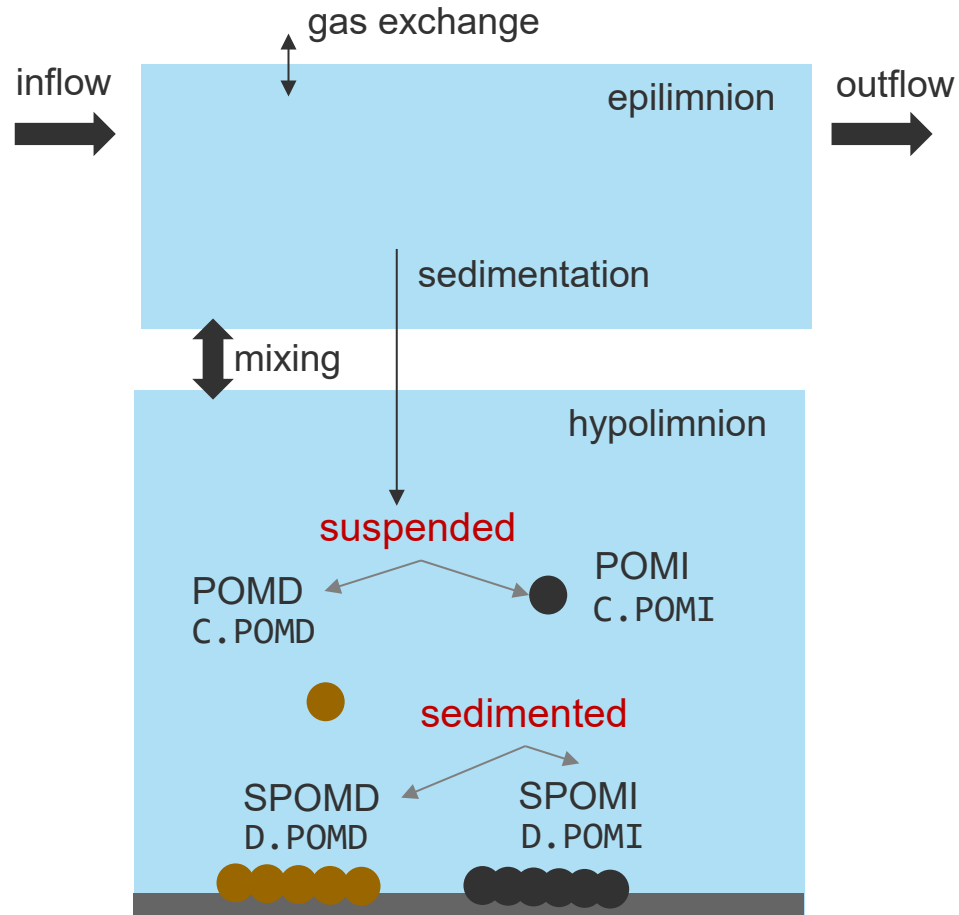

# Review Exercise 4

Process	Substances / Organisms									
	HPO <sub>4</sub> <sup>2-</sup> gP	NH <sub>4</sub> <sup>+</sup> gN	NO <sub>3</sub> <sup>-</sup> gN	O <sub>2</sub> gO	ALG gDM	ZOO gDM	POMD gDM	POMI gDM	SPOMD gDM	SPOMI gDM
Growth of algae NO <sub>3</sub> <sup>-</sup>	-		-	+	1					
Growth of algae NH <sub>4</sub> <sup>+</sup>	-	-		+	1					
Respiration of algae	+	+		-	-1					
Death of algae	0/+	0/+		0/+	-1		(1 - f <sub>I</sub> )Y <sub>ALG,death</sub>	f <sub>I</sub> Y <sub>ALG,death</sub>		
Growth of zooplankton	+	+		-	$\frac{-1}{Y_{ZOO}}$	1	$\frac{(1 - f_I)f_e}{Y_{ZOO}}$	$\frac{f_I f_e}{Y_{ZOO}}$		
Respiration of zoopl.	+	+		-		-1				
Death of zooplankton	0/+	0/+		0/+		-1	(1 - f <sub>I</sub> )Y <sub>ZOO,death</sub>	f <sub>I</sub> Y <sub>ZOO,death</sub>		
Nitrification		-1	+	-						
Oxic mineral. of org. part.	+	+		-			-1			
Ox. min. of org. part. in sed.	+	+		-					-1	
Anox. min. of org. part. in sed.	+	+	-						-1	
Sed. of deg. org. part.							-1		1	
Sed. of inert org. part.								-1		1

# Review Exercise 4

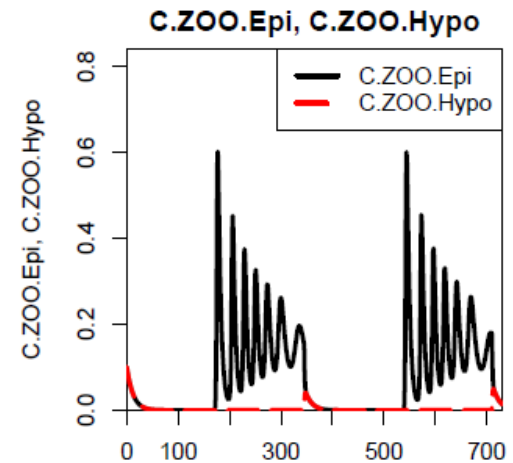
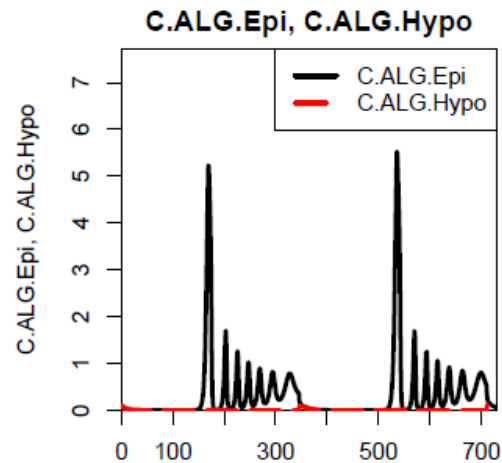
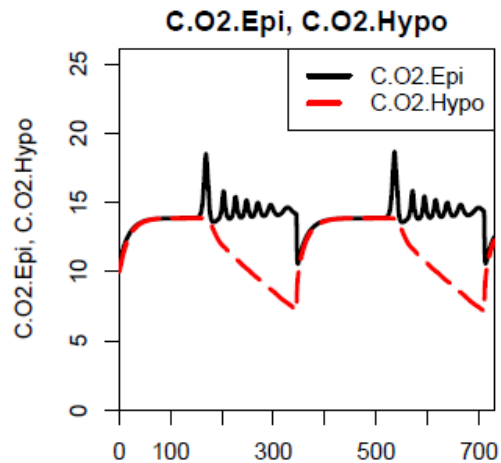
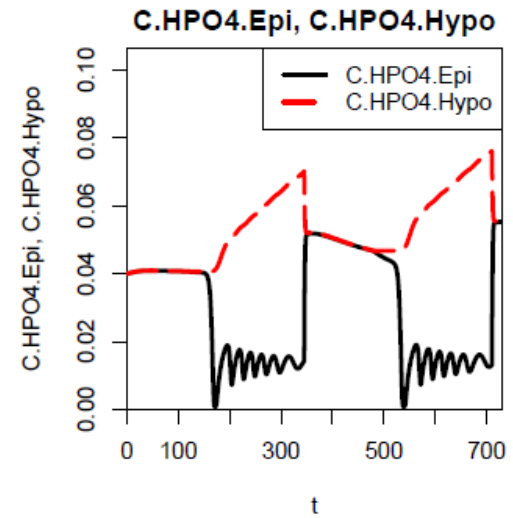
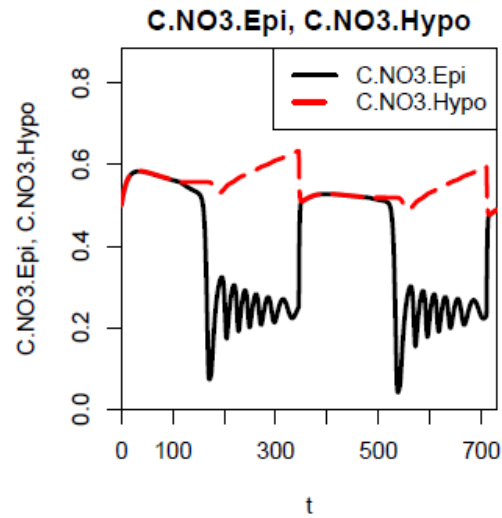
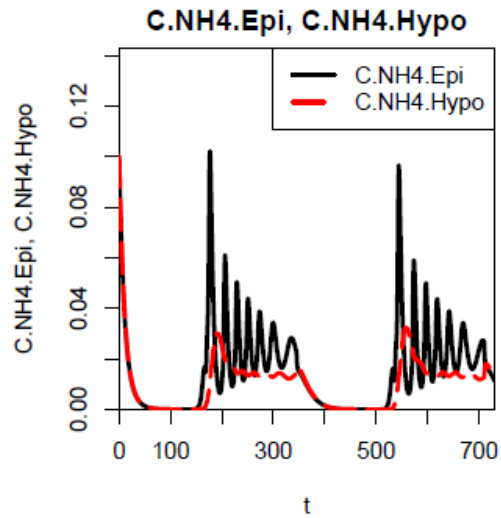

suspended  
degradable

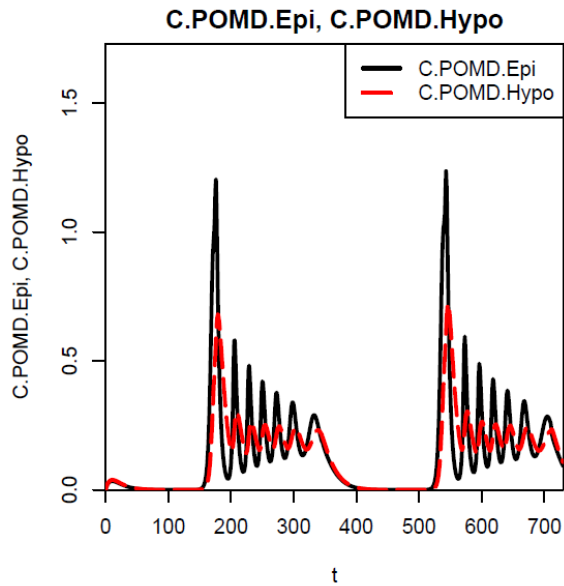

inert

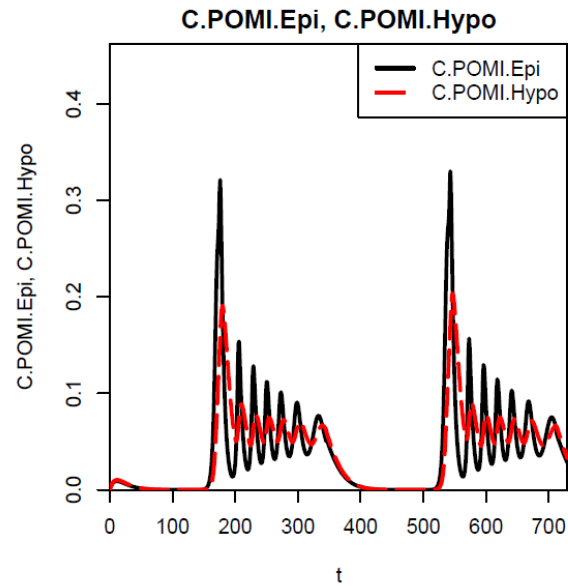

sedimented  
degradable / inert

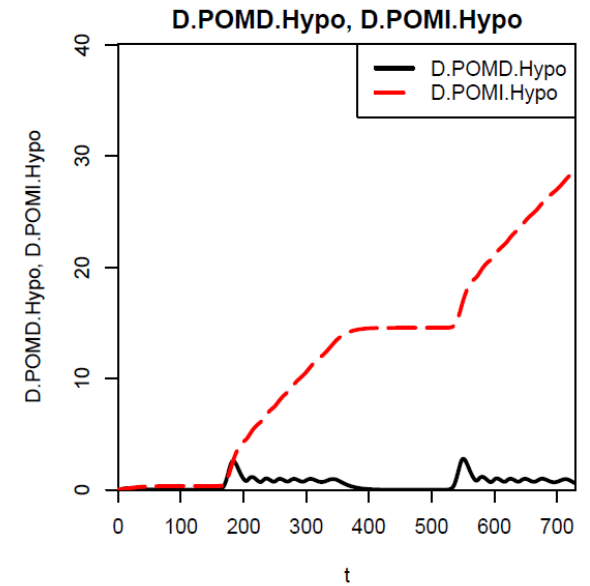

Do you have any questions about exercise 4 (or other topics)?

## Questions to think about:

- Why is it important that some stoichiometric coefficients are defined as  $0/+$  ?
- How is the metalimnion represented by the model?
- Look at the process rates of mineralization in the sediment. Why are they different than in chapter 8.5?
- Look at the mass balance for P and N. If there is a difference between input and output + accumulation, where does it come from? Hint: Have a look at the stoichiometric coefficients for anoxic mineralization

# Review Exercise 4

Process	Substances / Organisms									
	HPO <sub>4</sub> <sup>2-</sup> gP	NH <sub>4</sub> <sup>+</sup> gN	NO <sub>3</sub> <sup>-</sup> gN	O <sub>2</sub> gO	ALG gDM	ZOO gDM	POMD gDM	POMI gDM	SPOMD gDM	SPOMI gDM
Growth of algae NO <sub>3</sub> <sup>-</sup>	-		-	+	1					
Growth of algae NH <sub>4</sub> <sup>+</sup>	-	-		+	1					
Respiration of algae	+	+		-	-1					
Death of algae	0/+	0/+		0/+	-1		(1 - f <sub>I</sub> )Y <sub>ALG,death</sub>	f <sub>I</sub> Y <sub>ALG,death</sub>		
Growth of zooplankton	+	+		-	$\frac{-1}{Y_{ZOO}}$	1	$\frac{(1 - f_I)f_e}{Y_{ZOO}}$	$\frac{f_I f_e}{Y_{ZOO}}$		
Respiration of zoopl.	+	+		-		-1				
Death of zooplankton	0/+	0/+		0/+		-1	(1 - f <sub>I</sub> )Y <sub>ZOO,death</sub>	f <sub>I</sub> Y <sub>ZOO,death</sub>		
Nitrification		-1	+	-						
Oxic mineral. of org. part.	+	+		-			-1			
Ox. min. of org. part. in sed.	+	+		-					-1	
Anox. min. of org. part. in sed.	+	+	-						-1	
Sed. of deg. org. part.							-1		1	
Sed. of inert org. part.								-1		1

## Questions to think about:

- How is the metalimnion represented by the model?

```
# Definition of links:

# Exchange between epilimnion and hypolimnion:

metalimnion <-
  new(Class      = "link",
       name      = "Metalimnion",
       from      = "Epi",
       to        = "Hypo",
       qadv.spec = list(C.POMD = expression(v.sed.POM*A),
                       C.POMI = expression(v.sed.POM*A)),
       qdiff.gen = expression(A/h.meta*Kz))
```

- Look at the process rates of mineralization in the sediment. Why are they different than in chapter 8.5?

see p. 186f

chapter 8.5

$$\rho_{\text{miner,ox,POM}} = k_{\text{miner,ox,POM},T_0} \cdot \exp\left(\beta_{\text{BAC}}(T - T_0)\right) \cdot \frac{C_{\text{O}_2}}{K_{\text{O}_2,\text{miner}} + C_{\text{O}_2}} \cdot C_{\text{POM}}$$

$$\rho_{\text{miner,anox,POM}} = k_{\text{miner,anox,POM},T_0} \cdot \exp\left(\beta_{\text{BAC}}(T - T_0)\right) \cdot \frac{K_{\text{O}_2,\text{miner}}}{K_{\text{O}_2,\text{miner}} + C_{\text{O}_2}} \cdot \frac{C_{\text{NO}_3^-}}{K_{\text{NO}_3^-,\text{miner}} + C_{\text{NO}_3^-}} \cdot C_{\text{POM}}$$

concentrations at the location where mineralization happens

Model 11.4

$$\rho_{\text{miner,ox,SPOMD}} \left| \begin{array}{l} k_{\text{miner,ox,SPOMD},T_0} \cdot \exp\left(\beta_{\text{BAC}}(T - T_0)\right) \cdot \frac{C_{\text{O}_2}}{K_{\text{O}_2,\text{miner}} + C_{\text{O}_2}} \cdot \frac{D_{\text{SPOMD}}}{K_{\text{SPOM,miner,sed}} + D_{\text{SPOMD}}} \\ k_{\text{miner,anox,SPOMD},T_0} \cdot \exp\left(\beta_{\text{BAC}}(T - T_0)\right) \cdot \frac{C_{\text{NO}_3^-}}{K_{\text{NO}_3^-,\text{miner}} + C_{\text{NO}_3^-}} \cdot \left(\frac{D_{\text{SPOMD}}}{K_{\text{SPOM,miner,sed}} + D_{\text{SPOMD}}}\right)^2 \end{array} \right.$$

concentrations refer to the mixed box (= water column)

Diffusion limitation in the sediment is not modelled mechanistically.

## In a more realistic model

Sediment is modelled as different discrete/continuous layers/depth, each with its in-situ substance concentrations:

$$\rho_{\text{miner,ox,SPOMD}} = k_{\text{miner,ox}} \cdot f_{\text{temp}}(T) \cdot f_{\text{lim}}(C_{\text{O}_2}) \cdot C_{\text{SPOMD}}$$

$$\rho_{\text{miner,anox,SPOMD}} = k_{\text{miner,anox}} \cdot f_{\text{temp}}(T) \cdot f_{\text{inh}}(C_{\text{O}_2}) \cdot f_{\text{lim}}(C_{\text{NO}_3^-}) \cdot C_{\text{SPOMD}}$$

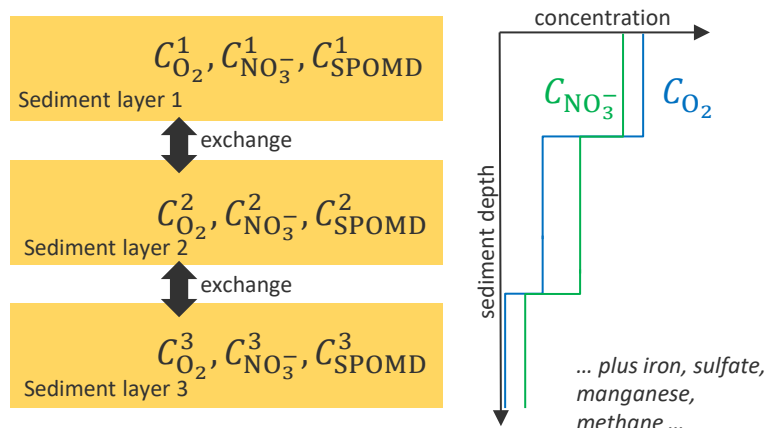

## In our two-box model

Sediment is modelled as density of SPOMD at the bottom of the hypolimnion, with substance concentrations of this box:

$$\rho_{\text{miner,ox,SPOMD}} = k_{\text{miner,ox}} \cdot f_{\text{temp}}(T) \cdot f_{\text{lim}}(C_{\text{O}_2}) \cdot \frac{D_{\text{SPOMD}}}{K_{\text{SPOMD,miner}} + D_{\text{SPOMD}}}$$

$$\rho_{\text{miner,anox,SPOMD}} = k_{\text{miner,anox}} \cdot f_{\text{temp}}(T) \cdot f_{\text{lim}}(C_{\text{NO}_3^-}) \cdot \frac{D_{\text{SPOMD}}^2}{K_{\text{SPOMD,miner}}^2 + D_{\text{SPOMD}}^2}$$

hypo  $C_{\text{O}_2}$ , hypo  $C_{\text{NO}_3^-}$

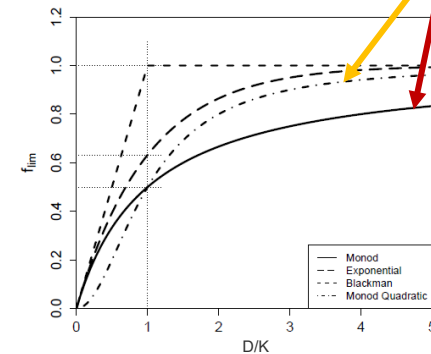

- Look at the mass balance for P and N. If there is a difference between input and output + accumulation, where does it come from?  
*Hint:* Have a look at the stoichiometric coefficients for anoxic mineralization

Flux	Substances	Phosphorus (t/a)	Nitrogen (t/a)
Input	$\text{HPO}_4^{2-}$ , $\text{NO}_3^-$	<b>12.6</b>	<b>158</b>
Output	$\text{HPO}_4^{2-}$ , $\text{NO}_3^-$ , $\text{NH}_4^+$	<b>9.3</b>	<b>127</b>
	ALG, ZOO, POMD, POMI	1.2	11.5
Accumulation difference in concentrations or densities between the end and start of the simulations	$\text{HPO}_4^{2-}$ , $\text{NO}_3^-$ , $\text{NH}_4^+$	<b>1.2</b>	<b>-7.4</b>
	ALG, ZOO, POMD, POMI	0.0	0.1
	SPOMD	0.0	0.2
	SPOMI	<b>1.0</b>	<b>8.6</b>
Loss	Denitrification of $\text{NO}_3^-$	0.0	<b>18.0</b>

- Look at the mass balance for P and N. If there is a difference between input and output + accumulation, where does it come from?  
*Hint:* Have a look at the stoichiometric coefficients for anoxic mineralization

Process	Substances / Organisms									Rate
	NH <sub>4</sub> <sup>+</sup> gN	NO <sub>3</sub> <sup>-</sup> gN	N <sub>2</sub> gN	HPO <sub>4</sub> <sup>2-</sup> gP	HCO <sub>3</sub> <sup>-</sup> gC	H <sup>+</sup> mol	H <sub>2</sub> O mol	POM gDM		
Anoxic miner.	+	-	+	+	+	?	?	-1		$\rho_{\text{miner,anox,POM}}$

Table 8.6: Process table of anoxic mineralization.

```
> print(round(nu,3))
```

	C.NH4	C.NO3	C.N2	C.HPO4	C.HCO3	C.O2	C.H	C.H2O	C.ALG	C.ZOO	C.POMD	D.POMD	C.POMI	D.POMI
gro.ALG.NH4	-0.060	0.000	0.000	-0.005	-0.365	0.937	-0.026	0.002	1	0	0.000	0	0.000	0
gro.ALG.NO3	0.000	-0.060	0.000	-0.005	-0.365	1.211	-0.035	-0.002	1	0	0.000	0	0.000	0
resp.ALG	0.060	0.000	0.000	0.005	0.365	-0.937	0.026	-0.002	-1	0	0.000	0	0.000	0
death.ALG	0.017	0.000	0.000	0.000	0.027	0.018	0.001	0.006	-1	0	0.571	0	0.143	0
gro.ZOO	0.180	0.000	0.000	0.008	0.992	-2.417	0.070	0.003	-5	1	0.800	0	0.200	0
resp.ZOO	0.060	0.000	0.000	0.010	0.360	-0.930	0.026	-0.002	0	-1	0.000	0	0.000	0
death.ZOO	0.014	0.000	0.000	0.005	0.000	0.088	-0.001	0.007	0	-1	0.609	0	0.152	0
nitri	-1.000	1.000	0.000	0.000	0.000	-4.571	0.143	0.071	0	0	0.000	0	0.000	0
miner.ox.POM	0.060	0.000	0.000	0.007	0.473	-1.338	0.036	-0.011	0	0	-1.000	0	0.000	0
miner.ox.POM.sed	0.060	0.000	0.000	0.007	0.473	-1.338	0.036	-0.011	0	0	0.000	-1	0.000	0
miner.anox.POM.sed	0.060	-0.468	0.468	0.007	0.473	0.000	0.002	0.006	0	0	0.000	-1	0.000	0
sed.POMD	0.000	0.000	0.000	0.000	0.000	0.000	0.000	0.000	0	0	-1.000	1	0.000	0
sed.POMI	0.000	0.000	0.000	0.000	0.000	0.000	0.000	0.000	0	0	0.000	0	-1.000	1

# Sensitivity Analysis

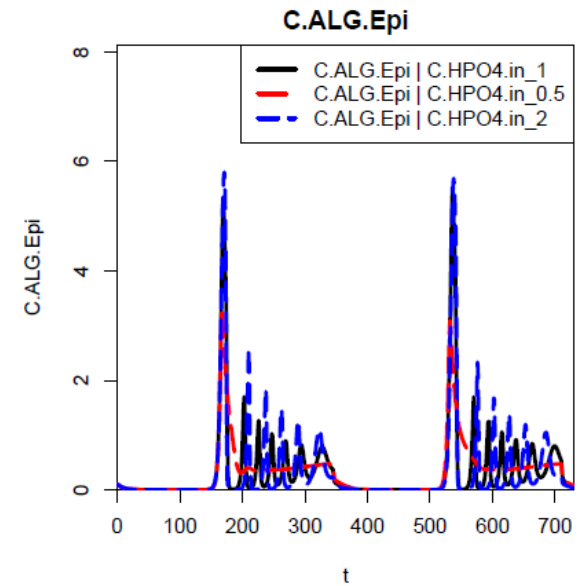
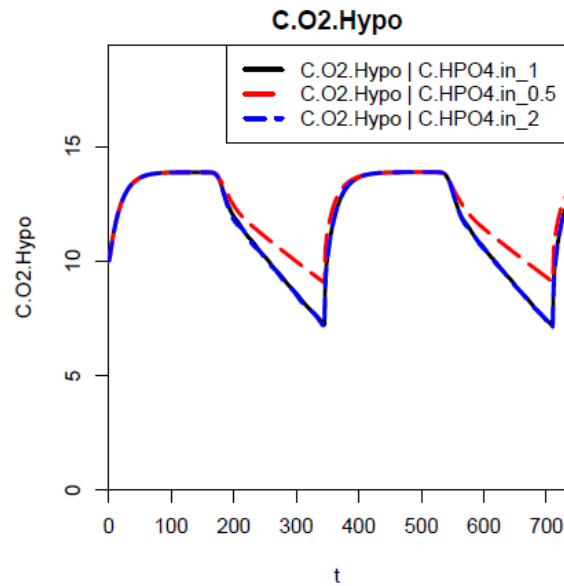
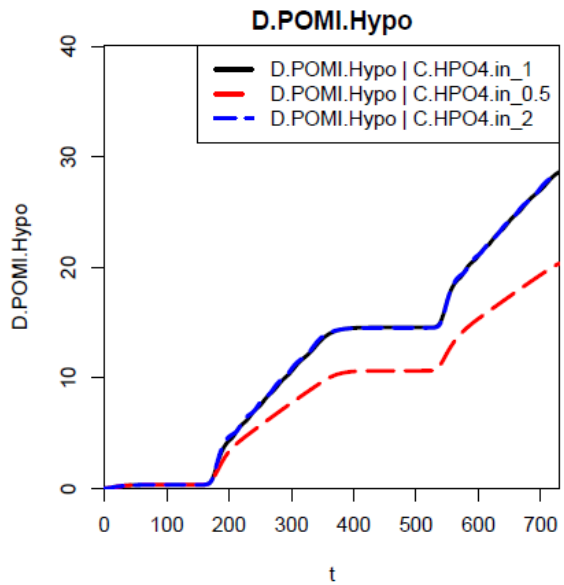
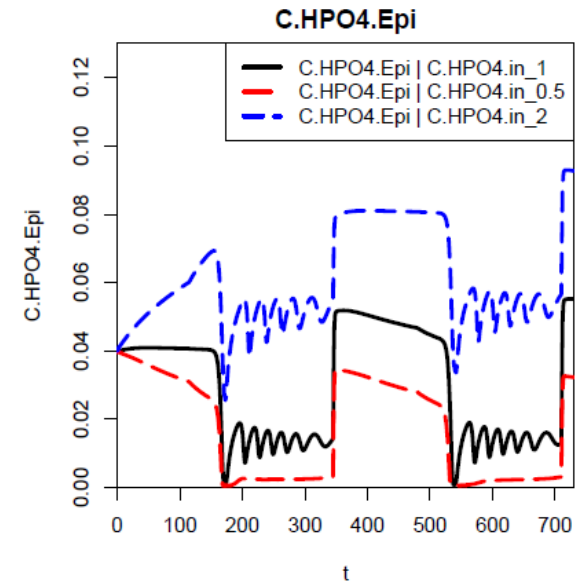
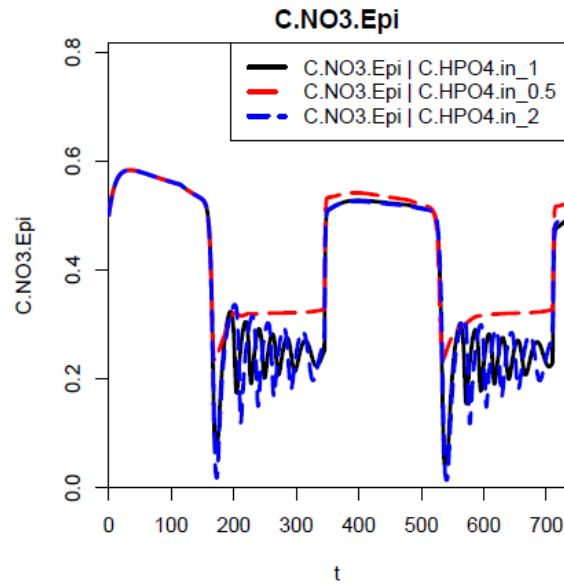
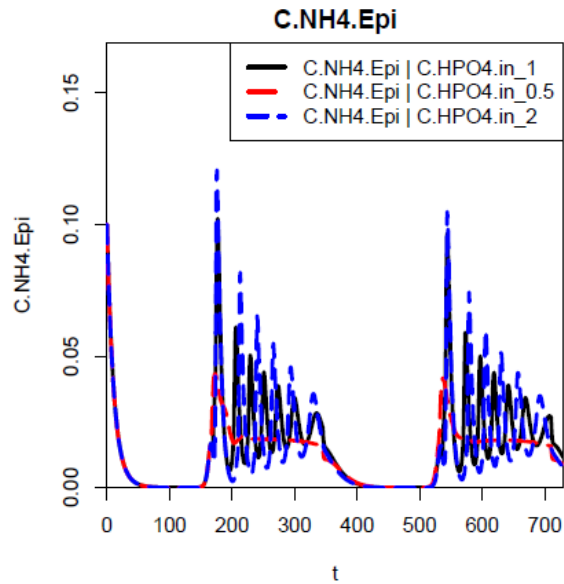

# Sensitivity Analysis

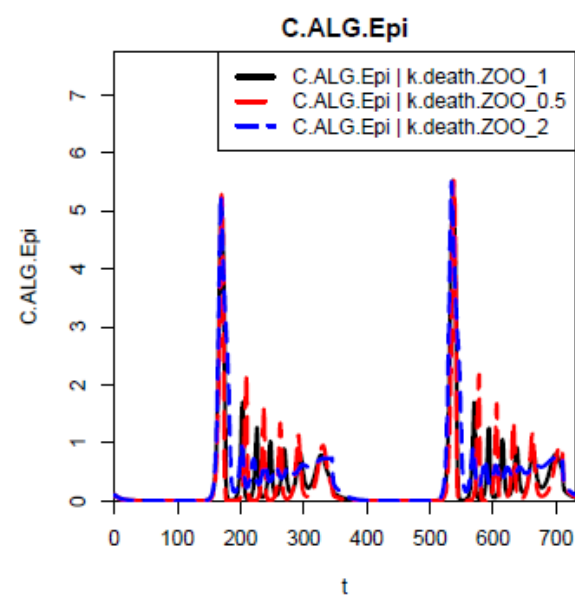
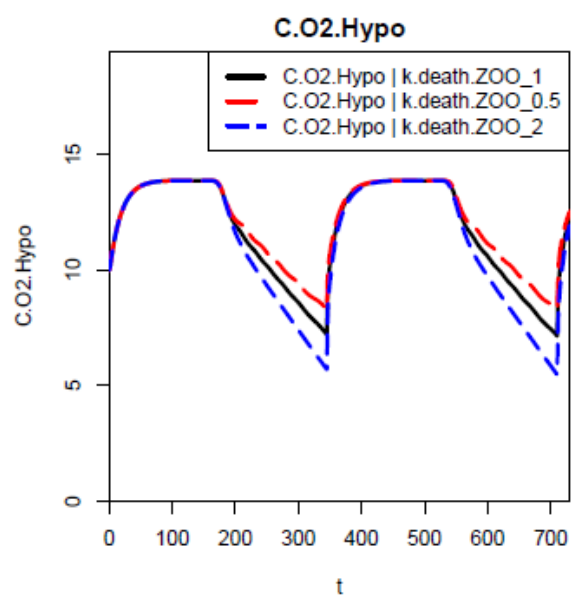
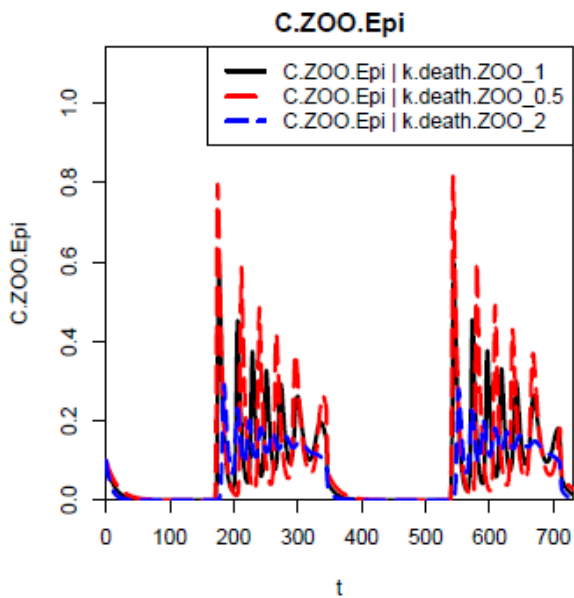
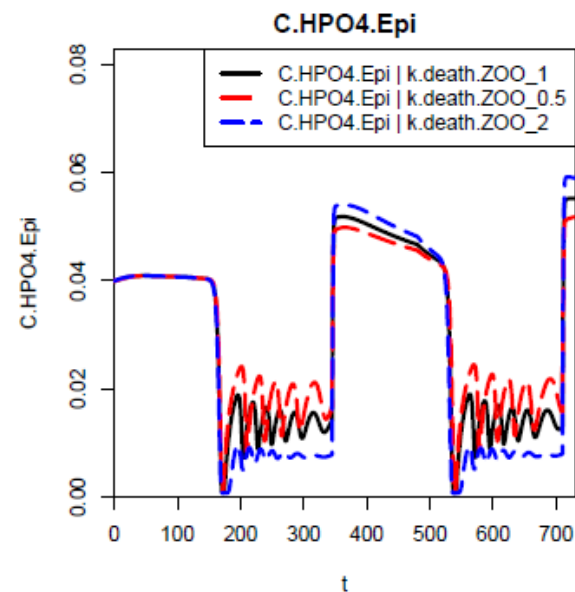
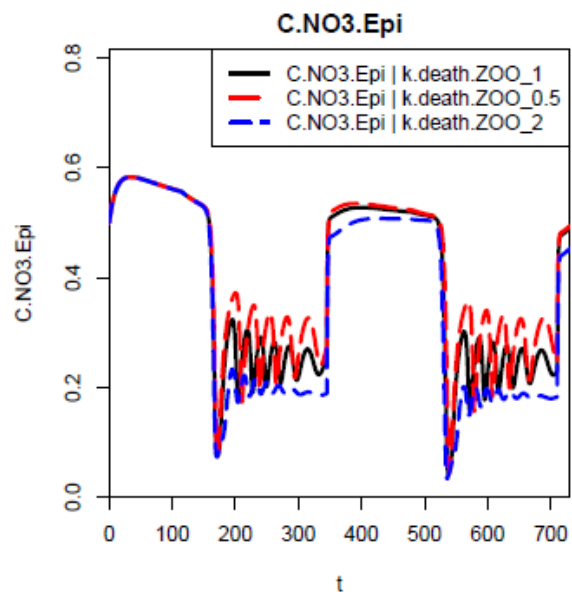
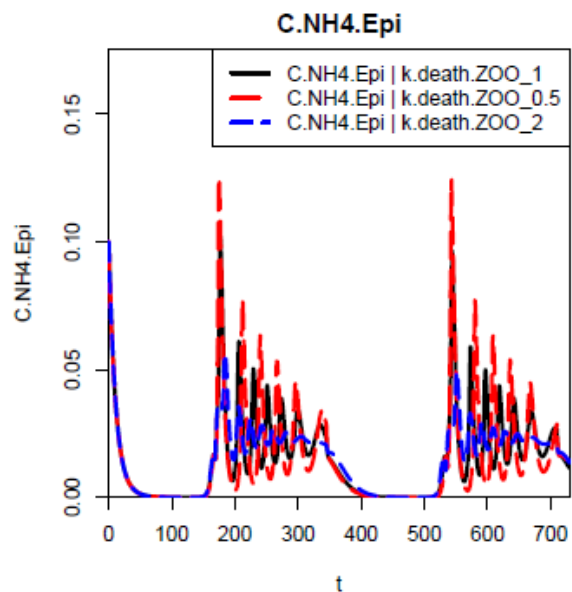

# Sensitivity Analysis

### C.NH4.Epi

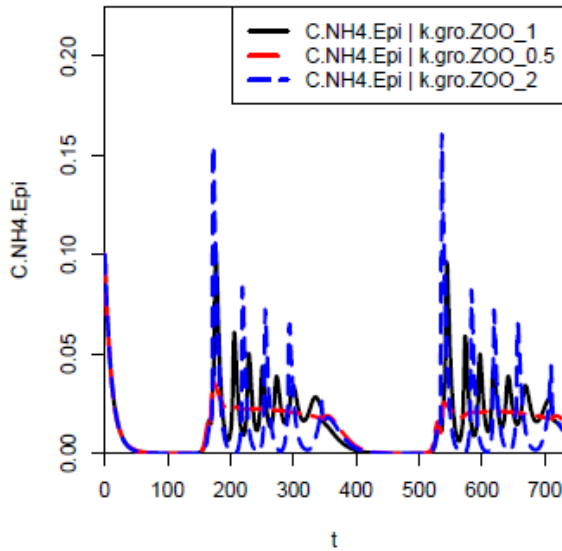

### C.NO3.Epi

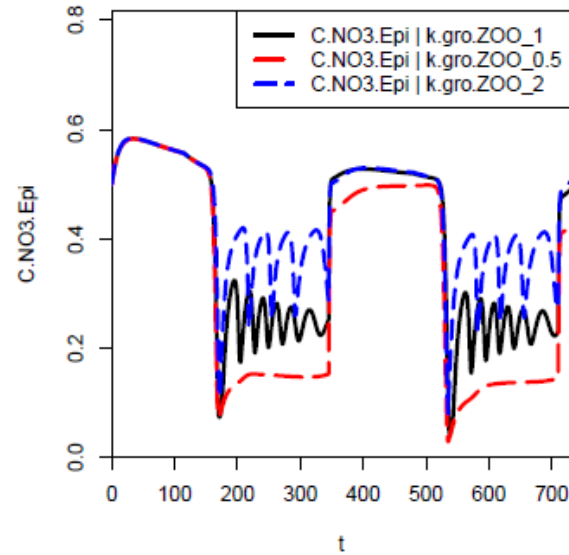

### C.HPO4.Epi

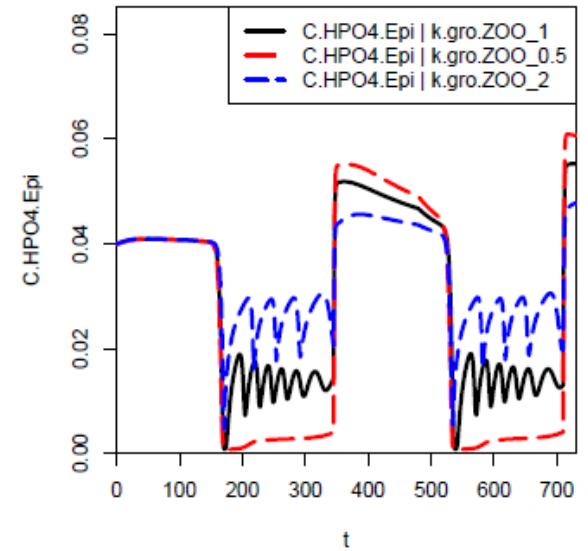

### C.ZOO.Epi

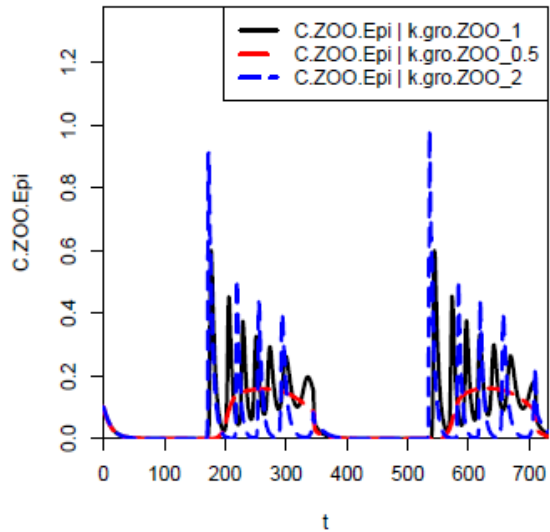

### C.O2.Hypo

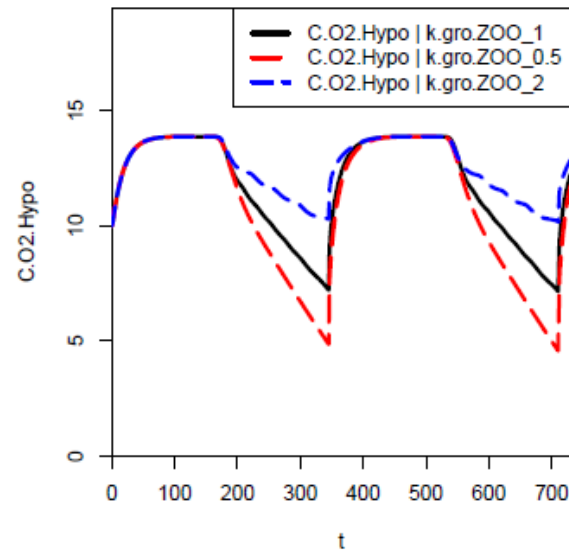

### C.ALG.Epi

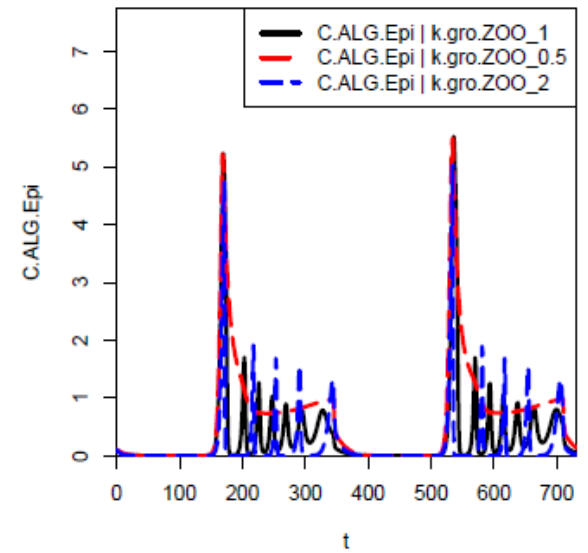





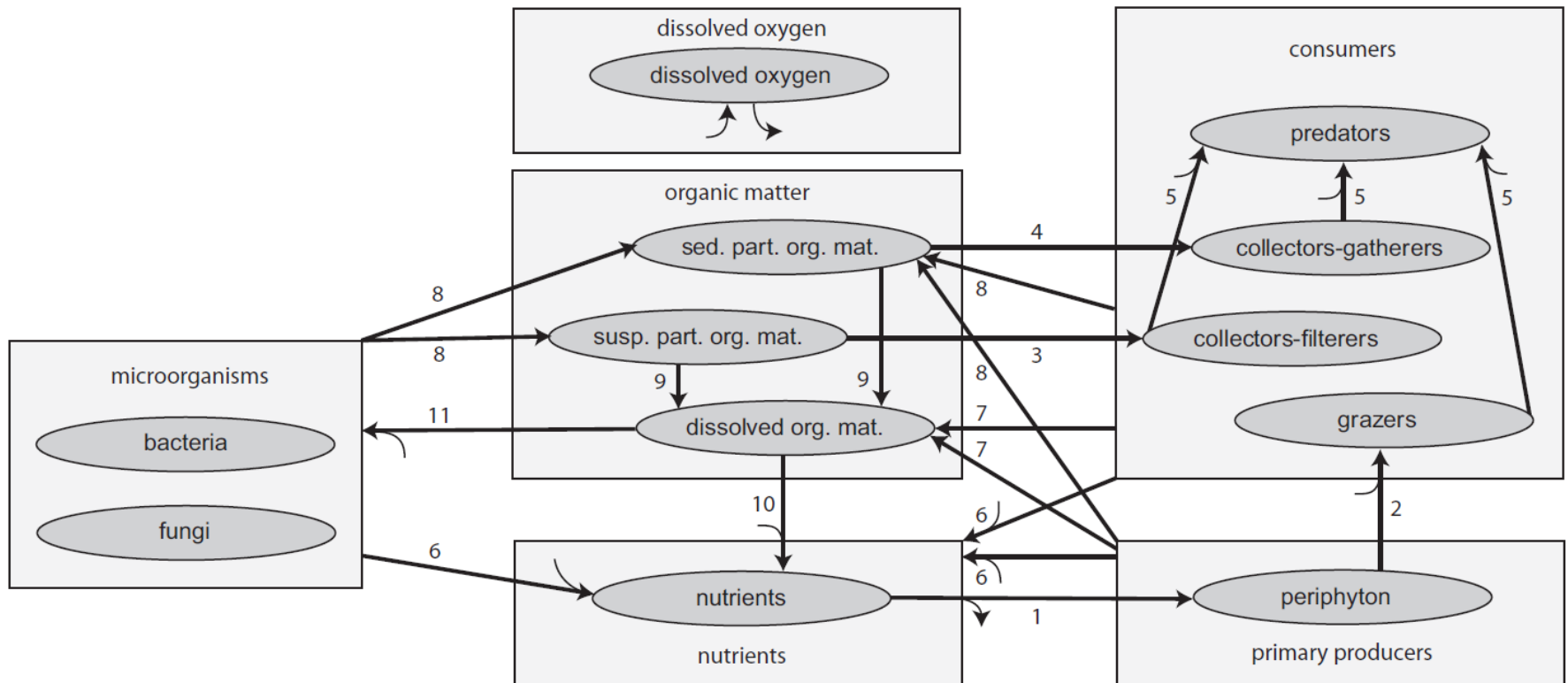

Heterotrophic organisms, such as bacteria and fungi are responsible for the decomposition of organic material.

So far, this was only considered implicitly when modelling mineralization.

We will now describe the overall process of mineralization of organic particles as **hydrolysis** of the particles to dissolved organic matter, **growth of heterotrophic bacteria**, and finally **death and respiration of the bacteria**.

# Classification of Growth Processes

energy source		electron donor		carbon source	
light:	<b>photo-</b>	organic comp.:	<b>organo-</b>	organic comp.:	<b>hetero-</b>
redox proc.:	<b>chemo-</b>	inorg. comp.:	<b>litho-</b>	inorg. comp.:	<b>auto-</b>

Algae and macrophytes: photolithoautotrophic

Heterotrophic bacteria: chemoorganoheterotrophic

Nitrifiers: chemolithoautotrophic

You: ?

Also mixotrophic organisms exist:

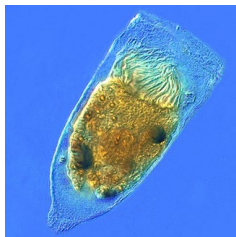

ciliates



sea slug



carnivorous plants



spotted salamander

## Stoichiometry:

Process	Substances / Organisms										Rate
	NH <sub>4</sub> <sup>+</sup> gN	NO <sub>3</sub> <sup>-</sup> gN	N <sub>2</sub> gN	HPO <sub>4</sub> <sup>2-</sup> gP	HCO <sub>3</sub> <sup>-</sup> gC	O <sub>2</sub> gO	H <sup>+</sup> mol	H <sub>2</sub> O mol	DOM g	HET gDM	
Oxgro. HET NH4	?			?	+	-	?	?	$-\frac{1}{Y_H}$	1	$\rho_{\text{gro,HET,ox,NH4}}$
Oxgro. HET NO3		?		?	+	-	?	?	$-\frac{1}{Y_H}$	1	$\rho_{\text{gro,HET,ox,NO3}}$
Anoxgro. HET		-	+	?	+		?	?	$-\frac{1}{Y_H}$	1	$\rho_{\text{gro,HET,anox}}$

## Constraints:

$$\nu_{\text{gro,HET,ox,NH4 HET}} + \nu_{\text{gro,HET,ox,NH4 DOM}} Y_{\text{HET}} = 0$$

$$\nu_{\text{gro,HET,ox,NO3 HET}} + \nu_{\text{gro,HET,ox,NO3 DOM}} Y_{\text{HET}} = 0$$

$$\nu_{\text{gro,HET,anox,NH4 HET}} + \nu_{\text{gro,HET,anox,NH4 DOM}} Y_{\text{HET}} = 0$$

## Process rates for oxic growth:

$$\rho_{\text{gro,HET,ox,NH}_4^+} = k_{\text{gro,HET,ox,T}_0} \cdot \exp\left(\beta_{\text{BAC}}(T - T_0)\right) \left[ \frac{p_{\text{NH}_4^+, \text{HET}} C_{\text{NH}_4^+}}{p_{\text{NH}_4^+, \text{HET}} C_{\text{NH}_4^+} + C_{\text{NO}_3^-}} \right]$$

$$\cdot \min \left( \frac{C_{\text{DOM}}}{K_{\text{DOM,HET}} + C_{\text{DOM}}}, \frac{C_{\text{O}_2}}{K_{\text{O}_2, \text{HET}} + C_{\text{O}_2}}, \left[ \frac{C_{\text{HPO}_4^{2-}}}{K_{\text{HPO}_4^{2-}, \text{HET}} + C_{\text{HPO}_4^{2-}}} \right], \left[ \frac{C_{\text{NH}_4^+} + C_{\text{NO}_3^-}}{K_{\text{N,HET}} + C_{\text{NH}_4^+} + C_{\text{NO}_3^-}} \right] \right) \cdot C_{\text{HET}}$$

$$\rho_{\text{gro,HET,ox,NO}_3^-} = k_{\text{gro,HET,ox,T}_0} \cdot \exp\left(\beta_{\text{BAC}}(T - T_0)\right) \left[ \frac{C_{\text{NO}_3^-}}{p_{\text{NH}_4^+, \text{HET}} C_{\text{NH}_4^+} + C_{\text{NO}_3^-}} \right]$$

$$\cdot \min \left( \frac{C_{\text{DOM}}}{K_{\text{DOM,HET}} + C_{\text{DOM}}}, \frac{C_{\text{O}_2}}{K_{\text{O}_2, \text{HET}} + C_{\text{O}_2}}, \left[ \frac{C_{\text{HPO}_4^{2-}}}{K_{\text{HPO}_4^{2-}, \text{HET}} + C_{\text{HPO}_4^{2-}}} \right], \left[ \frac{C_{\text{NH}_4^+} + C_{\text{NO}_3^-}}{K_{\text{N,HET}} + C_{\text{NH}_4^+} + C_{\text{NO}_3^-}} \right] \right) \cdot C_{\text{HET}}$$

[ ... ] only needed if the corresponding stoichiometric coefficients are negative

Process rates for anoxic growth:

$$\rho_{\text{gro,HET,anox}} = k_{\text{gro,HET,anox}} \cdot \exp\left(\beta_{\text{BAC}}(T - T_0)\right) \cdot \frac{K_{\text{O}_2,\text{HET}}}{K_{\text{O}_2,\text{HET}} + C_{\text{O}_2}} \cdot \min\left(\frac{C_{\text{DOM}}}{K_{\text{DOM,HET}} + C_{\text{DOM}}}, \frac{C_{\text{NO}_3}}{K_{\text{NO}_3,\text{HET}} + C_{\text{NO}_3}}, \left[\frac{C_{\text{HPO}_4}}{K_{\text{HPO}_4,\text{HET}} + C_{\text{HPO}_4}}\right]\right) \cdot C_{\text{HET}}$$

**Nitrification is mediated by nitrifying bacteria.**

**Different organisms are responsible for the two steps of nitrification:**

- N1: First step of nitrification from ammonium to nitrite (e.g. *Nitrosomonas*)
- N2: Second step of nitrification from nitrite to nitrate (e.g. *Nitrobacter*)

## Stoichiometry:

Process	Substances / Organisms										Rate
	$\text{NH}_4^+$ gN	$\text{NO}_2^-$ gN	$\text{NO}_3^-$ gN	$\text{HPO}_4^{2-}$ gP	$\text{HCO}_3^-$ gC	$\text{O}_2$ gO	$\text{H}^+$ mol	$\text{H}_2\text{O}$ mol	N1 gDM	N2 gDM	
Growth of N1	$-\frac{1}{Y_{\text{N1}}}$	+	-	-	-	-	?	?	1		$\rho_{\text{gro,N1}}$
Growth of N2		$-\frac{1}{Y_{\text{N2}}}$	+	-	-	-	?	?		1	$\rho_{\text{gro,N2}}$

## Rates:

$$\rho_{\text{gro,N1}} = k_{\text{gro,N1},T_0} \cdot \exp\left(\beta_{\text{N1}}(T - T_0)\right) \cdot \min\left(\frac{C_{\text{NH}_4}}{K_{\text{NH}_4,\text{nitri}} + C_{\text{NH}_4}}, \frac{C_{\text{O}_2}}{K_{\text{O}_2,\text{nitri}} + C_{\text{O}_2}}, \frac{C_{\text{HPO}_4}}{K_{\text{HPO}_4,\text{nitri}} + C_{\text{HPO}_4}}\right) \cdot C_{\text{N1}}$$

$$\rho_{\text{gro,N2}} = k_{\text{gro,N2},T_0} \cdot \exp\left(\beta_{\text{N2}}(T - T_0)\right) \cdot \min\left(\frac{C_{\text{NO}_2}}{K_{\text{NO}_2,\text{nitri}} + C_{\text{NO}_2}}, \frac{C_{\text{O}_2}}{K_{\text{O}_2,\text{nitri}} + C_{\text{O}_2}}, \frac{C_{\text{HPO}_4}}{K_{\text{HPO}_4,\text{nitri}} + C_{\text{HPO}_4}}\right) \cdot C_{\text{N2}}$$

What are advantages and disadvantages of modelling heterotrophic and nitrifying bacteria explicitly?

# Transport Processes in a River

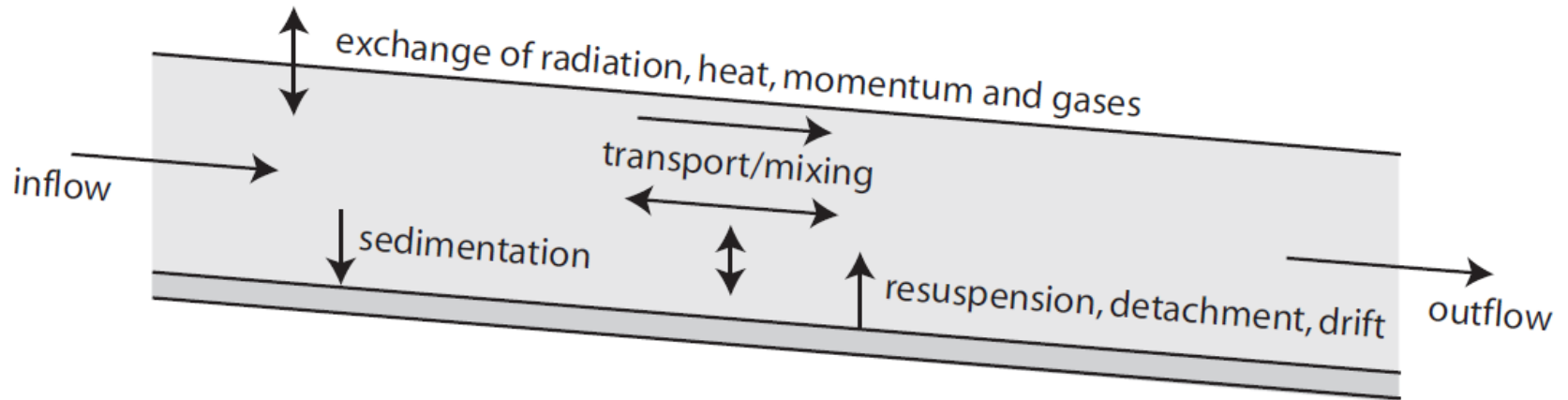

## chapter 6.1.2

Overview of substance transport and mixing processes in rivers under steady-state hydraulic conditions:

- the estimation of average flow velocity and water depth
- vertical mixing
- lateral mixing
- longitudinal transport and dispersion

We often know the geometry and discharge of a river,  
but we have to estimate the average **flow velocity** and **water depth**

What do you think:

What affects the flow velocity in a river?

What affects the water depth?



Steady-state hydraulics: average flow velocity  $v$  and water depth  $h$  depend on discharge  $Q$  and the geometry of the river bed.

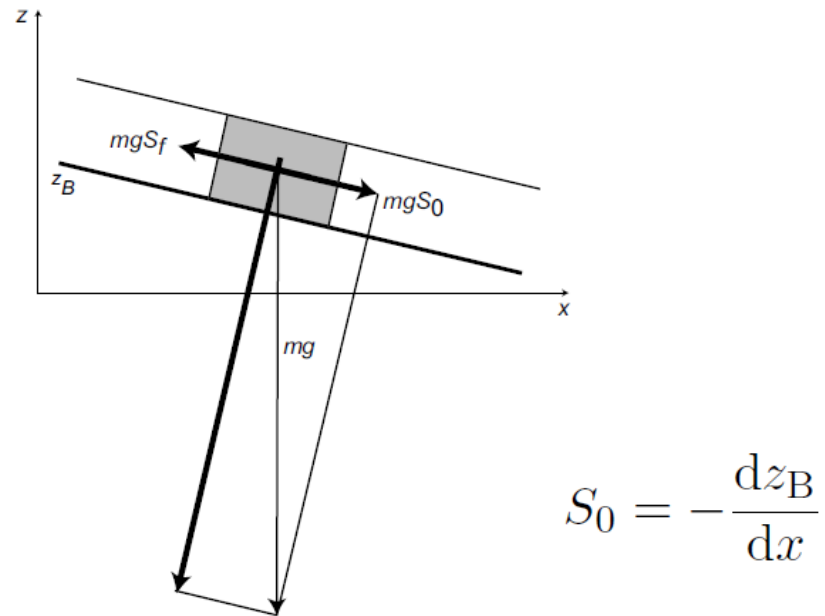

$z_B$ : vertical coordinate of the river bed,  $x$ : distance along the river,  
 $S_f$ : non-dimensional friction force,  $S_0$ : slope of the river bed,  $m$ : mass,  
 $g$ : gravitational acceleration

hydraulic radius  $R = \frac{\text{cross-sectional area } A}{\text{wetted perimeter } P}$

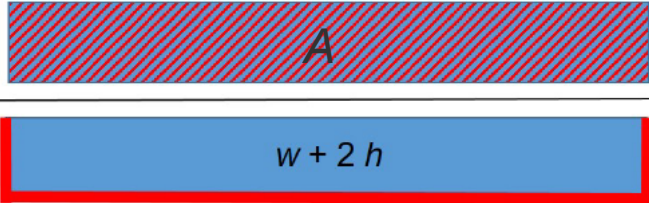

for a wide rectangular river bed:  $P = w + 2h \approx w$       $R = \frac{A}{P} \approx \frac{A}{w}$

Assumption: prismatic river reach, constant friction, no backwater:

$$S_f = S_0$$

**Friction** is caused by surface roughness and irregularities of the river bed, by irregularities in channel geometry, obstructions, vegetation and curves.

All these causes generate **dissipation** (loss of kinetic energy in the open system due to conversion into heat).

This is a very complex process that cannot be accounted for mechanistically in simple, one-dimensional models.

To estimate the friction force, we use a simple parameterization as a function of averaged flow quantities, geometry of the riverbed and surface roughness.

Friction force made non-dimensional by division through the gravitational force of the fluid, formulation after Darcy-Weisbach and Manning-Strickler.

$$\begin{array}{ccc} \text{Darcy-Weisbach} & \text{Strickler} & \text{Manning} \\ S_f = \frac{f}{8g} \frac{1}{R} \frac{Q^2}{A^2}, & S_f = \frac{1}{K_{st}^2} \frac{1}{R^{4/3}} \frac{Q^2}{A^2} = n^2 \frac{1}{R^{4/3}} \frac{Q^2}{A^2}, & n = \frac{1}{K_{st}} \end{array}$$

$f$ : non-dimensional friction-factor,  $Q$ : discharge,  $A$ : wetted cross-sectional area,  $R$ : hydraulic radius ( $A$  divided by wetted perimeter),  $K_{st}$ : Friction coefficient according to Strickler,  $n$ : friction coefficient according to Manning

$$S_f = \frac{1}{K_{st}^2} \frac{1}{R^{4/3}} \frac{Q^2}{A^2}$$

substituting:  $S_f = S_0$ ;  $R = \frac{A}{P} \approx \frac{A}{w}$ ;  $A = \frac{Q}{v}$

$$S_0 = \frac{1}{K_{st}^2} \frac{1}{\left(\frac{Q}{v}\right)^{4/3}} \frac{Q^2}{\left(\frac{Q}{v}\right)^2}$$

solving for  $v$  :

$$v = \left(K_{st} \sqrt{S_0}\right)^{\frac{3}{5}} \left(\frac{Q}{w}\right)^{\frac{2}{5}}$$

with  
non-dimensional friction force  $S_f$   
Strickler coefficient  $K_{st}$ ,  
hydraulic radius  $R$ ,  
discharge  $Q$ ,  
cross sectional area  $A$ ,  
wetted perimeter  $P$ ,  
river width  $w$ ,  
flow velocity  $v$ ,  
slope  $S_0$

similar for Darcy-Weissbach and Manning equation:

$$v = \left( \frac{8g}{f} S_0 \frac{Q}{w} \right)^{\frac{1}{3}} \text{ (Darcy-Weissbach)}$$

$$v = \left( K_{st} \sqrt{S_0} \right)^{\frac{3}{5}} \left( \frac{Q}{w} \right)^{\frac{2}{5}} = \left( \frac{\sqrt{S_0}}{n} \right)^{\frac{3}{5}} \left( \frac{Q}{w} \right)^{\frac{2}{5}} \text{ (Strickler-Manning)}$$

$K_{st} = 1/n$

$$h = \frac{Q}{wv}$$

Estimation of the Manning coefficient:

Category	Property	Contribution to friction		
Surface material of the river bed	earth	$n_1 =$	0.020	$s/m^{1/3}$
	fine gravel		0.024	$s/m^{1/3}$
	coarse gravel		0.028	$s/m^{1/3}$
Irregularities of the river bed	smooth	$n_2 =$	0.000	$s/m^{1/3}$
	minor		0.005	$s/m^{1/3}$
	moderate		0.010	$s/m^{1/3}$
	severe		0.020	$s/m^{1/3}$
Variation of shape of the cross-section	gradual	$n_3 =$	0.000	$s/m^{1/3}$
	occasional		0.005	$s/m^{1/3}$
	frequent		0.010 - 0.015	$s/m^{1/3}$
Obstructions in the river bed	negligible	$n_4 =$	0.000	$s/m^{1/3}$
	minor		0.010 - 0.015	$s/m^{1/3}$
	appreciable		0.020 - 0.030	$s/m^{1/3}$
	severe		0.040 - 0.060	$s/m^{1/3}$
Vegetation	none	$n_5 =$	0.000	$s/m^{1/3}$
	low		0.005 - 0.010	$s/m^{1/3}$
	medium		0.010 - 0.025	$s/m^{1/3}$
	high		0.025 - 0.050	$s/m^{1/3}$
	very high		0.050 - 0.100	$s/m^{1/3}$
Effect of curves	minor	$n_6 =$	0.000	$s/m^{1/3}$
	appreciable		$0.15 \sum_{i=1}^5 n_i$	
	severe		$0.30 \sum_{i=1}^5 n_i$	

## River Glatt

$$S_o = 0.0034$$

With a mean width of about 16 m, a slope of 0.34 % and a discharge of 4 m<sup>3</sup>/s we get the following values for mean flow velocity and mean depth:

	winter			summer			
$n_1$	=	0.028	s/m <sup>1/3</sup>	$n_1$	=	0.028	s/m <sup>1/3</sup>
$n_2$	=	0.005	s/m <sup>1/3</sup>	$n_2$	=	0.005	s/m <sup>1/3</sup>
$n_3$	=	0.000	s/m <sup>1/3</sup>	$n_3$	=	0.000	s/m <sup>1/3</sup>
$n_4$	=	0.000	s/m <sup>1/3</sup>	$n_4$	=	0.000	s/m <sup>1/3</sup>
$n_5$	=	0.010	s/m <sup>1/3</sup>	$n_5$	=	0.050	s/m <sup>1/3</sup>
$n_6$	=	0.000	s/m <sup>1/3</sup>	$n_6$	=	0.000	s/m <sup>1/3</sup>
$n$	=	0.043	s/m <sup>1/3</sup>	$n$	=	0.083	s/m <sup>1/3</sup>
$K_{st}$	=	23	m <sup>1/3</sup> /s	$K_{st}$	=	12	m <sup>1/3</sup> /s
		winter			summer		
$v$	=	?	m/s	$v$	=	?	m/s
$h$	=	?	m	$h$	=	?	m

## River Glatt

With a mean width of about 16 m, a slope of 0.34 ‰ and a discharge of 4 m<sup>3</sup>/s we get the following values for mean flow velocity and mean depth:

	winter			summer		
$n_1$	=	0.028	s/m <sup>1/3</sup>	$n_1$	=	0.028 s/m <sup>1/3</sup>
$n_2$	=	0.005	s/m <sup>1/3</sup>	$n_2$	=	0.005 s/m <sup>1/3</sup>
$n_3$	=	0.000	s/m <sup>1/3</sup>	$n_3$	=	0.000 s/m <sup>1/3</sup>
$n_4$	=	0.000	s/m <sup>1/3</sup>	$n_4$	=	0.000 s/m <sup>1/3</sup>
$n_5$	=	0.010	s/m <sup>1/3</sup>	$n_5$	=	0.050 s/m <sup>1/3</sup>
$n_6$	=	0.000	s/m <sup>1/3</sup>	$n_6$	=	0.000 s/m <sup>1/3</sup>
$n$	=	0.043	s/m <sup>1/3</sup>	$n$	=	0.083 s/m <sup>1/3</sup>
$K_{st}$	=	23	m <sup>1/3</sup> /s	$K_{st}$	=	12 m <sup>1/3</sup> /s
	winter			summer		
$v$	=	0.68	m/s	$v$	=	0.46 m/s
$h$	=	0.36	m	$h$	=	0.54 m

## Zürcher Unterland



Das Mähboot kommt aus Holland, der Bootsführer braucht dafür eine Extraprüfung.



Stundenlang stehen die Männer mit ihren Sensen im Wasser. Fotos: Sibylle Meier

# Mit Boot und Sensen die Glatt mähen

Dieses Jahr ist der Wasserhahnenfuss besonders stark gewachsen. Zwölf Arbeiter stutzen nun bei Opfikon das Gras, um Hochwasser zu verhindern.

### Von Andreas Frei

Opfikon - In grossen Ballen treibt der abgemähte Wasserhahnenfuss die Glatt hinunter in Richtung Flughafen. Auf der Höhe des Opfiker Werkhofs wird das Gras mit einer Maschine auf eine Flussseite in ein aufgestelltes Gitter getrieben. Dort holt Hermann Meier, Betriebsleiter Gewässerunterhalt in Oberriggold, die Pflanzenteile mit einer riesigen Greifzange aus dem Nass.

vom Hahnenfuss befreien. Sie sind beim Amt für Abfall, Wasser, Energie und Luft (Awel) des Kantons angestellt. Für die Hahnenfussentfernung arbeiten sie mit den Opfikern zusammen.

### Sechs Meter langes Gras

Ein paar Hundert Meter vom Auffanggitter entfernt mäht Albert Spühler das Gras mit einem Spezialboot, das am Bug einen drei Meter breiten, T-förmigen

Bei einem Wasserfall neben der abgebrannten Holzbrücke kommt das Boot nicht mehr weiter. Auch dort staut sich der Hahnenfuss bereits in grossen Mengen und muss später mit einem Spezialkran entfernt werden.

Flussaufwärts mähen drei weitere Werkarbeiter. Ruedi Meier, Remo Bossard und Andreas Perren stehen mitten in der Glatt und rücken dem Hahnenfuss nur mit ihren Sensen zu Leibe.

wir es vorziehen mussten.» Weshalb das so ist, sei nicht klar. «Temperatur, Wasserhöhe und Licht haben einen Einfluss. Wieso es jetzt aber bei etwa gleichen Voraussetzungen viel mehr Gras als letztes Jahr hat, können wir nicht erklären.»

### Hahnenfuss

Hochwassergefahr durch Pflanze

- **Advection:** directional transport with the water flow
- **Diffusion:** spreading of mass from highly concentrated areas to less concentrated areas due to unidirectional motion;  
Molecular diffusion (caused by Brownian motion)  
Turbulent diffusion (caused by turbulence eddies)
- **Dispersion:** spreading of mass from highly concentrated areas to less concentrated areas due to differences in flow velocity at different flow paths and mixing between the flow paths by diffusion

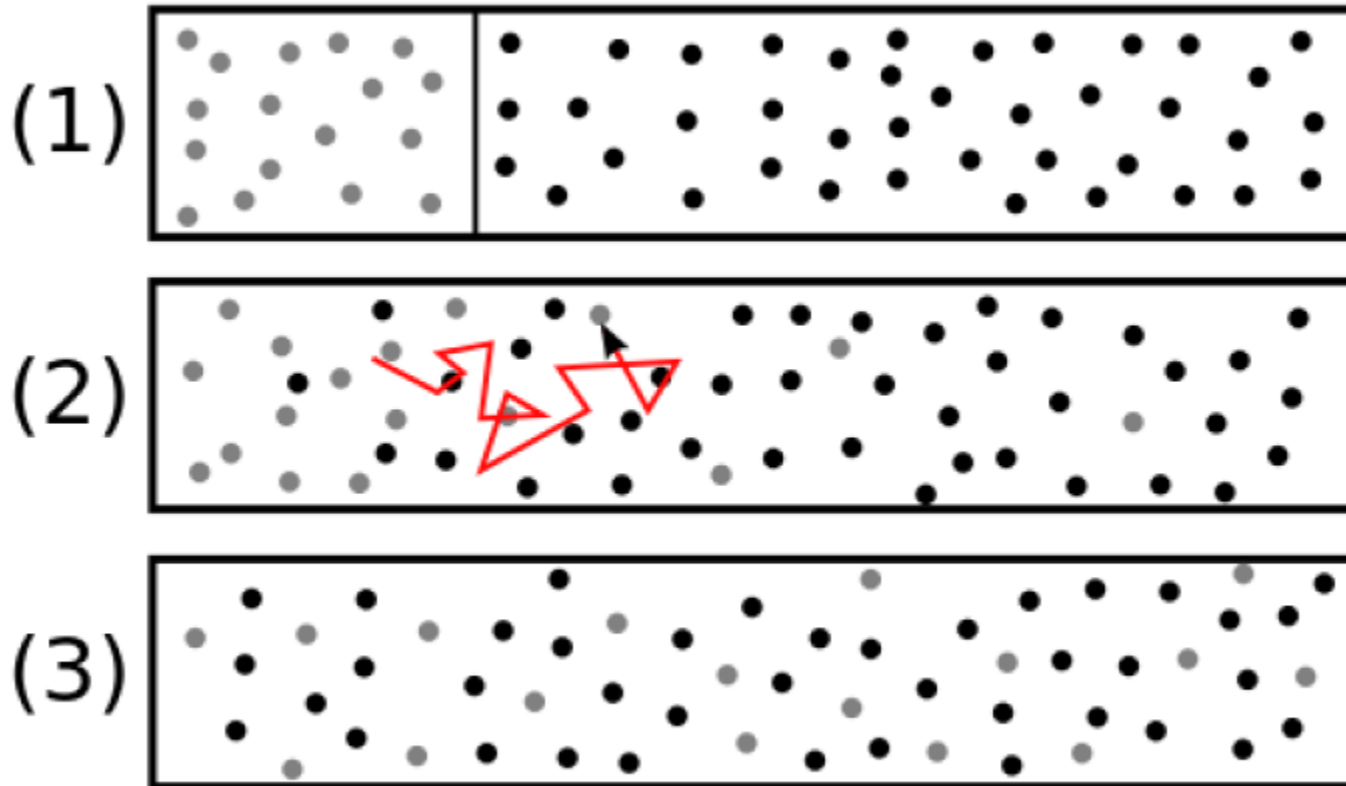

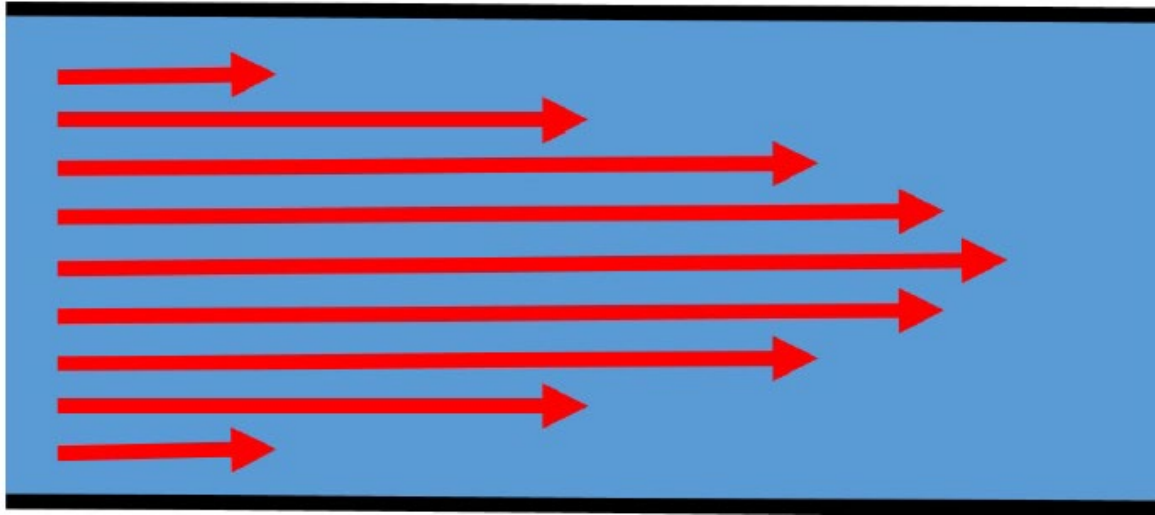

view from above

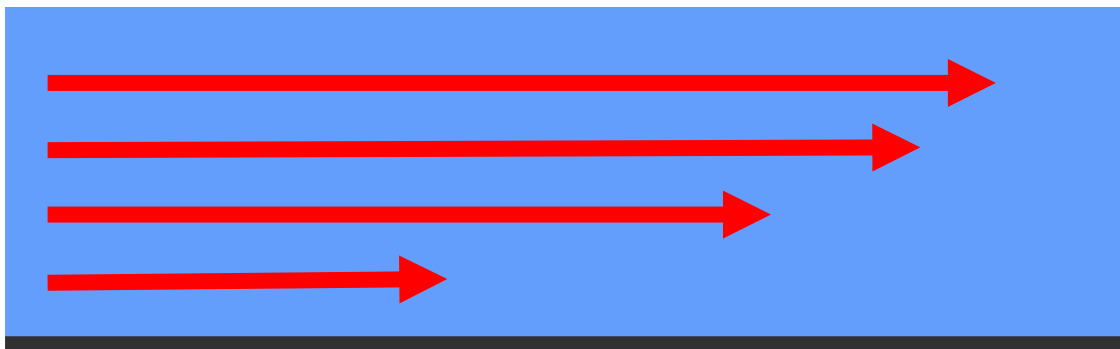

view from the side

Simple estimate of dispersal of a substance transported in a river using analytical solutions of the transport equation.

Simplifying assumptions:

- constant flow velocity  $v$  in time and across river cross-section
- constant vertical turbulent diffusion coefficient  $K_z$
- constant lateral diffusion and dispersion coefficient  $e_y$

Transport equation:

$$\frac{\partial C}{\partial t} = -v \frac{\partial C}{\partial x} + e_y \frac{\partial^2 C}{\partial y^2} + K_z \frac{\partial^2 C}{\partial z^2}$$

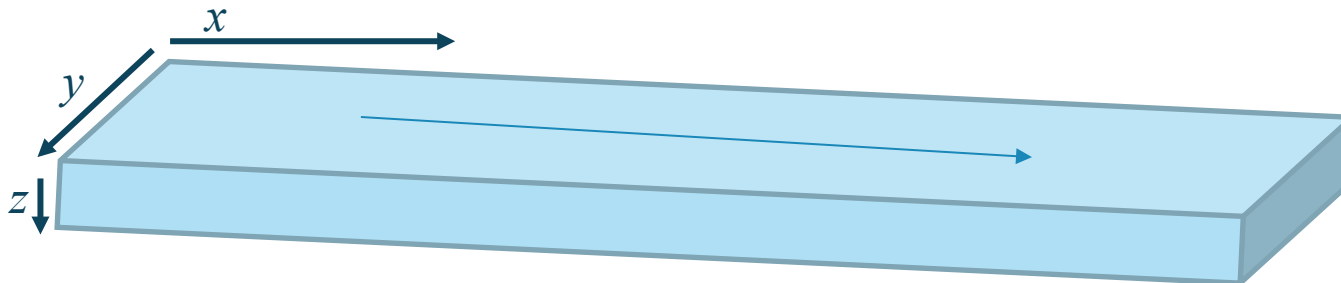

Assumption: Substance enters the river well mixed over the river depth, vertical dimension and time dependence can be ignored:

$$v \frac{\partial C}{\partial x} = e_y \frac{\partial^2 C}{\partial y^2}$$

Analytical solution for a substance entering the river at its bank and no considerable concentration reaching the other bank:

$$C(x, y, z) = \frac{J}{h} \frac{1}{v} \frac{1}{\sqrt{2\pi}} \frac{1}{\sigma_y(x)} \exp\left(-\frac{(y - y_0)^2}{2\sigma_y(x)^2}\right), \quad \sigma_y(x) = \sqrt{2e_y \frac{x}{v}}$$

$J$ : mass flux of the substance entering the river at its bank,  $h$ : water depth,  $y_0$ :  $y$ -coordinate of this bank

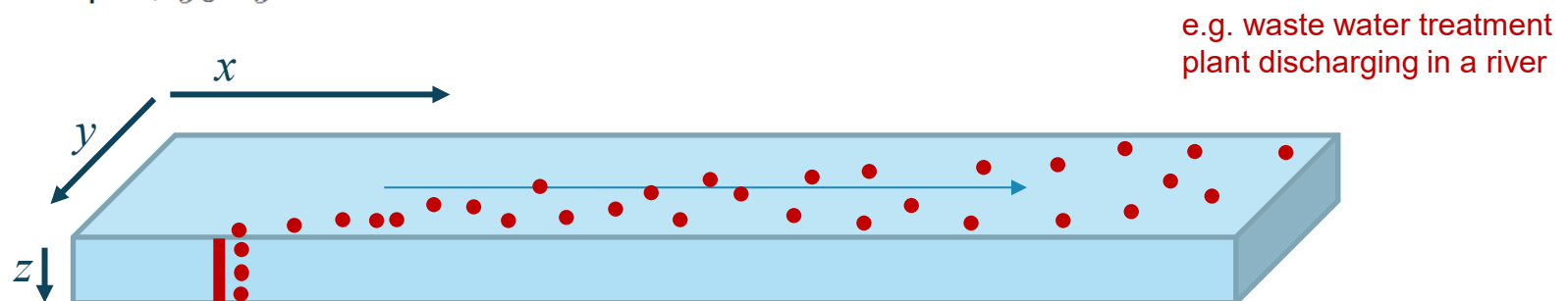

For longer flow distances along the river, the no-flow boundary condition at the other bank must be taken into account and the solution must be extended:

$$C(x, y, z) = \frac{J}{h} \frac{1}{v} \frac{2}{\sqrt{2\pi}} \frac{1}{\sigma_y(x)} \sum_{n=-\infty}^{\infty} \exp\left(-\frac{(y - y_0 - 2 \cdot nw)^2}{2\sigma_y(x)^2}\right)$$

Due to the fast decrease of the exponential function, in most cases only a small number of terms must be considered in this sum.

Estimation of the lateral extension of the substance distribution (close to the point of entrance into the river):

$$L_y \approx 2\sigma_y(x) = 2\sqrt{2e_y \frac{x}{v}}$$

Estimation of the maximum concentration with a rectangular distribution with half of this width:

$$C_{\max} \approx \frac{J}{hv} \frac{1}{\min(\sigma_y(x), w)} = \frac{J}{hv} \frac{1}{\min\left(\sqrt{2e_y \frac{x}{v}}, w\right)}$$

Far from the input site, the maximum concentration is equal to the concentration after complete mixing across the cross-sectional area.

## Lateral mixing distance:

Distance along the river, after which the substance is nearly homogeneously mixed in lateral direction

Definition: distance, after which the standard deviation  $\sigma_y(x)$  of the lateral substance distribution is equal to the river width.

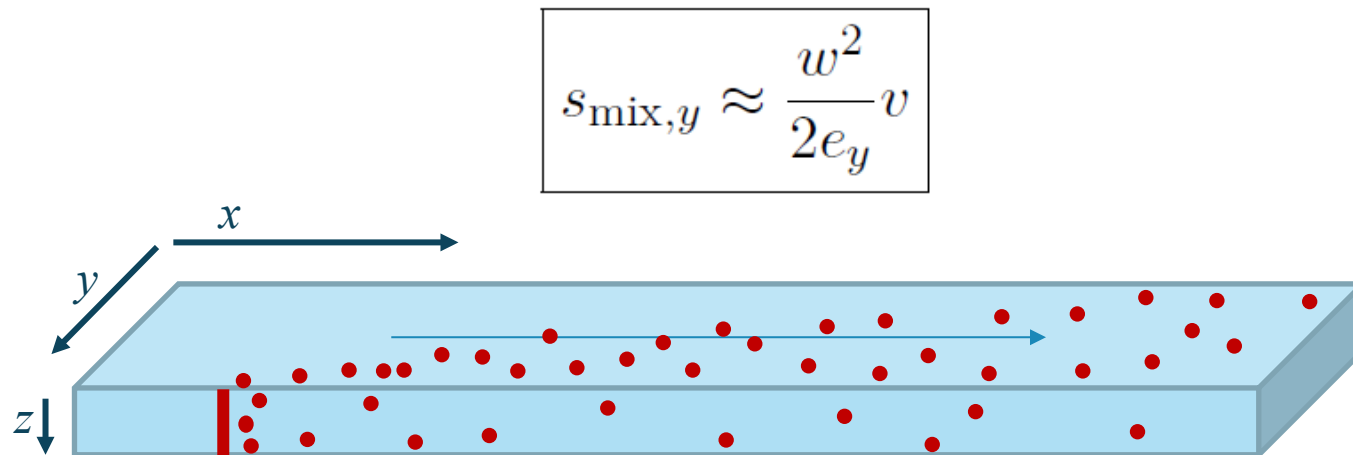

Estimation of the coefficient of lateral turbulent diffusion plus dispersion  $e_y$ :

$$\tau_0 \approx \rho g h S_0 \quad , \quad u^* = \sqrt{\frac{\tau_0}{\rho}} \quad , \quad u^* \approx \sqrt{g h S_0}$$

$$K_x \approx K_y \approx \theta_K u^* h \quad , \quad \theta_K \approx 0.15$$

$$\boxed{e_y \approx \theta_e u^* h} \quad , \quad \theta_e \approx 0.6$$

$K_x$ : coefficient of horizontal turbulent diffusion,  $K_y$ : coefficient of lateral turbulent diffusion,  $\theta_K$ : proportionality factor for lateral turbulent diffusion,  $u^*$ : shear velocity,  $h$ : water depth,  $\theta_e$ : proportionality factor for lateral turbulent diffusion plus dispersion

## River Glatt

With a mean width of about 16 m, a slope of 0.34 % and a discharge of 4 m<sup>3</sup>/s

	winter		summer
$e_y$	=	0.024 m <sup>2</sup> /s	$e_y$ = 0.043 m <sup>2</sup> /s
$s_{\text{mix},y}$	=	3600 m	$s_{\text{mix},y}$ = 1400 m

Note that mixing distances in a river with a width of 16 m can already be of considerable length. This must be considered when taking water samples downstream of tributaries or pollutant discharge sites.

# Lateral mixing



# Transport and longitudinal dispersion

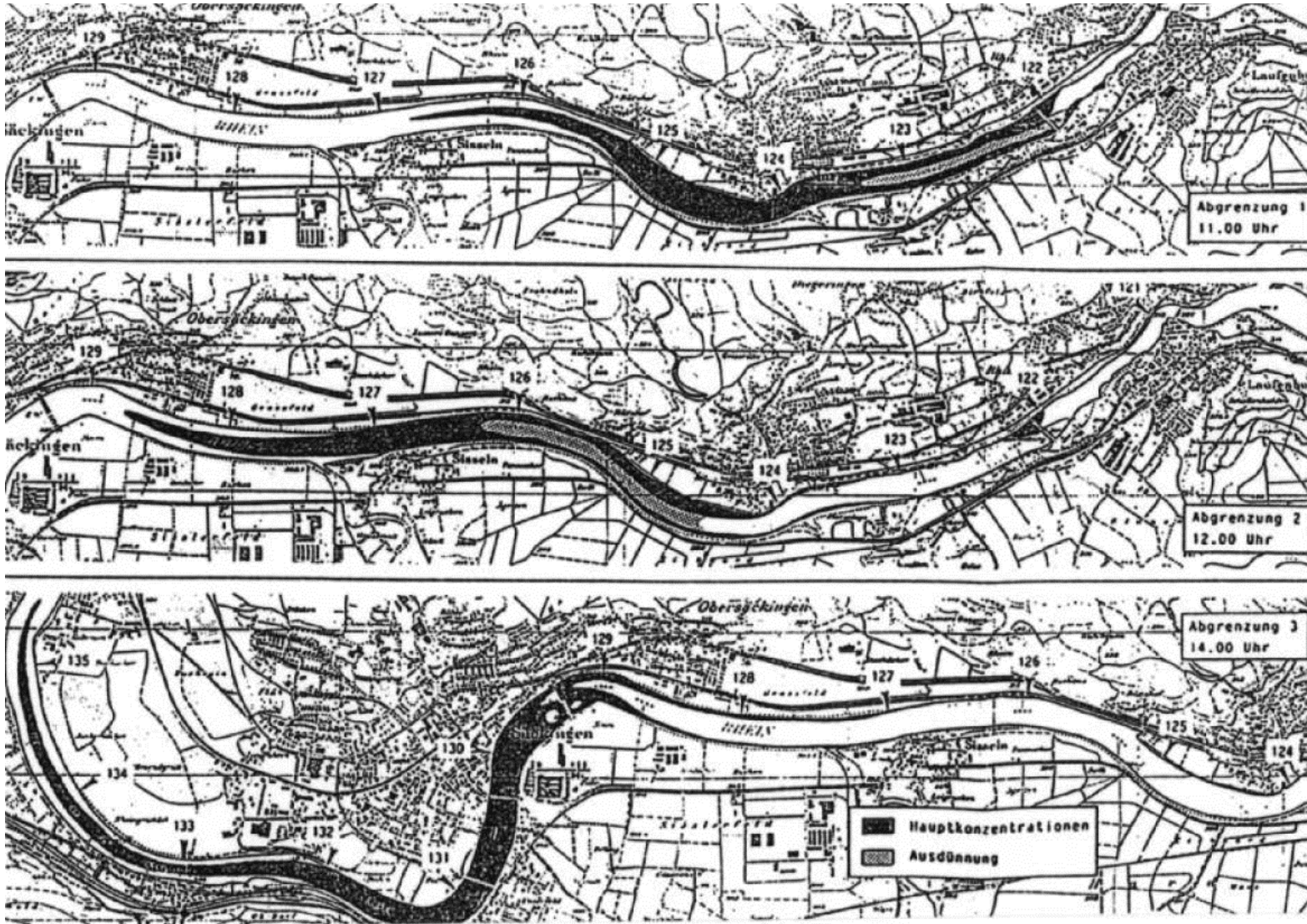

Simple estimate of longitudinal dispersal of a substance transported in a river using analytical solutions of the one-dimensional transport (advections-dispersion) equation.

$$\frac{\partial C}{\partial t} = -v \frac{\partial C}{\partial x} + E_x \frac{\partial^2 C}{\partial x^2}$$

$E_x$ : coefficient of longitudinal dispersion,  $v$ : mean flow velocity

Solution of the transport equation for a pulse input of mass  $m$ :

$$C(x, t) = \frac{m}{hw} \frac{1}{\sqrt{2\pi}} \frac{1}{\sigma_x(t)} \exp\left(-\frac{(x - vt)^2}{2\sigma_x(t)^2}\right), \quad \sigma_x(t) = \sqrt{2E_x t}$$

$w$ : width of the river,  $h$ : mean water depth,  $v$ : mean flow velocity,  
 $E_x$ : longitudinal dispersion coefficient

Estimation of the longitudinal dispersion coefficient  $E_x$

$$E_x \approx c_f \frac{w^2 v^2}{u^* h}, \quad c_f \approx 0.011$$

- Dispersion increases with increasing velocity differences across the river
- Dispersion increases with increasing width of the river, because of decreasing lateral mixing
- Dispersion decreases with lateral turbulent diffusivity ( $u^* h$ ), as this increases mixing across the river

$w$ : width of the river,  $v$ : mean flow velocity,  $u^*$ : shear velocity,  $h$ : mean water depth,  $c_f$ : non-dimensional proportionality factor

Estimation of the position of the pulse:

$$s_x \approx vt$$

Estimation of the length of the pulse

$$L_x \approx 4\sigma_x(t) = 4\sqrt{2E_x t}$$

Estimation of the maximum concentration (rectangular pulse with half of this length)

$$C_{\max} \approx \frac{m}{hw} \frac{1}{2\sigma_x(t)} = \frac{m}{hw} \frac{1}{2\sqrt{2E_x t}}$$

## River Glatt

$$\begin{array}{ccc} \text{winter} & & \text{summer} \\ \hline E_x & = & 33 \text{ m}^2/\text{s} & E_x & = & 8 \text{ m}^2/\text{s} \end{array}$$

The significantly stronger mixing across the width of the river reduces longitudinal dispersion considerably in summer compared to the winter situation. Note that the length of the pulse depends only on the square root of  $E_x$ .

## Transport and longitudinal dispersion in a box model:

Many simple models of rivers approximate the river by a sequence of mixed reactors. The distance along the river is divided into sections of length  $\Delta x$ . The volume  $V$  of the reactors can be described by:

$$V = wh\Delta x$$

Mixing within these boxes results in longitudinal dispersion with an equivalent dispersion coefficient given by:

$$E_x = \frac{v\Delta x}{2} = \frac{Q\Delta x}{2wh}$$

This effect is called "numerical diffusion".

# Benthic Population, O, N, P in a River

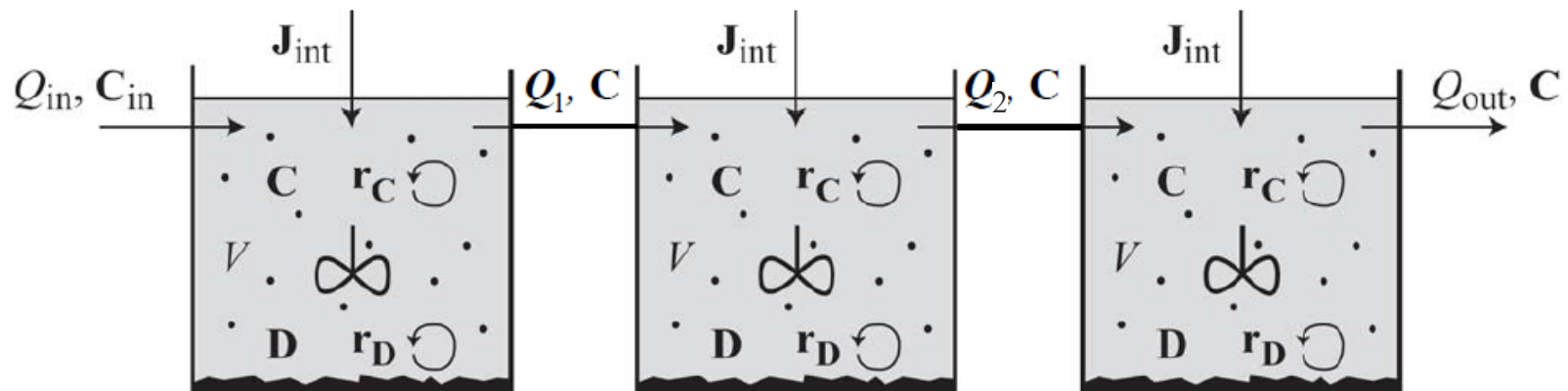

# Benthic Population, O, N, P in a River

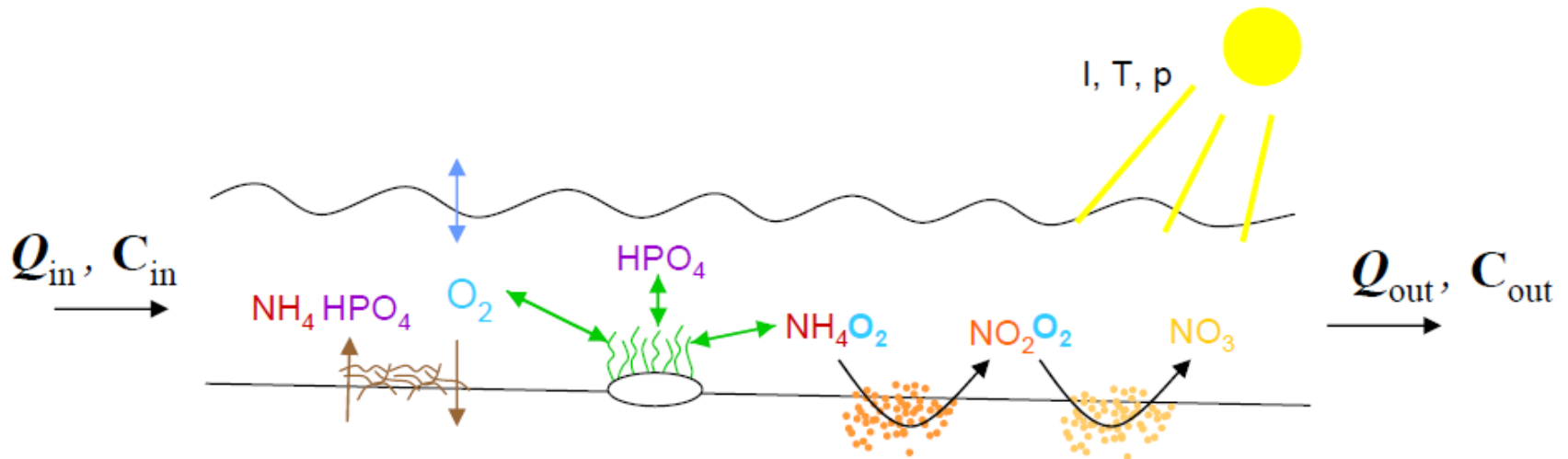

# Benthic Population, O, N, P in a River

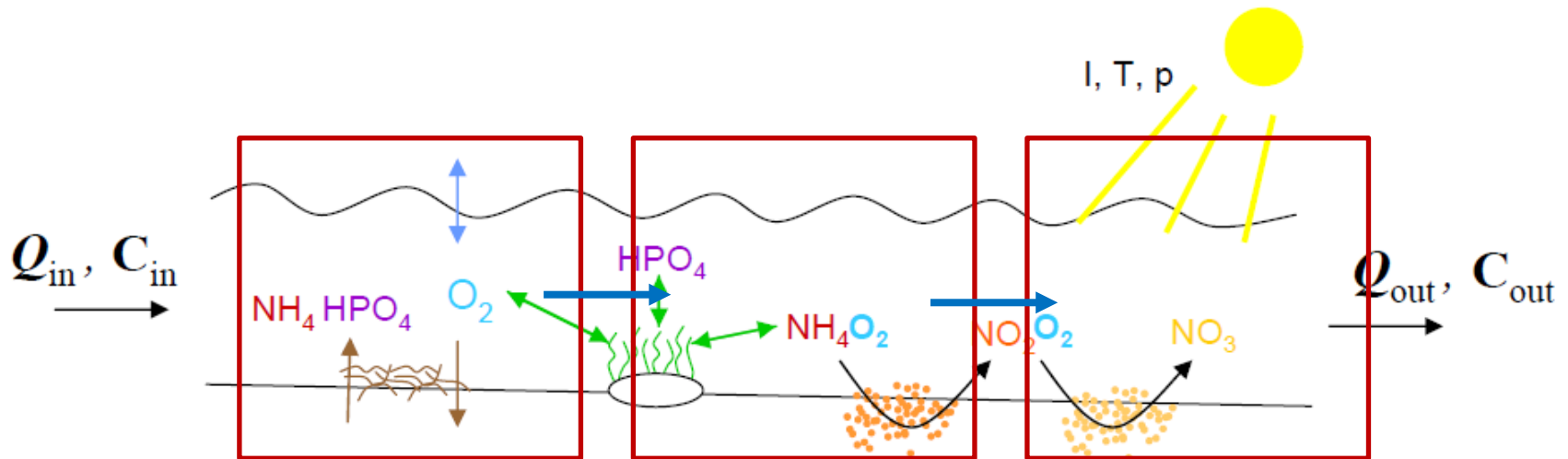

# Benthic Population, O, N, P in a River

	Process	Substances / Organisms										Rate	
		HPO <sub>4</sub> <sup>2-</sup> gP	NH <sub>4</sub> <sup>+</sup> gN	NO <sub>2</sub> <sup>-</sup> gN	NO <sub>3</sub> <sup>-</sup> gN	O <sub>2</sub> gO	DOM g	SALG gDM	SHET gDM	SN1 gDM	SN2 gDM		SPOM gDM
Algae	Growth of alg. NH4	-	-			+		1					$\rho_{gro,SALG,NH4}$
	Growth of alg. NO3	-			-	+		1					$\rho_{gro,SALG,NO3}$
	Respiration of algae	+	+			-		-1					$\rho_{resp,SALG}$
	Death of algae	0/+	0/+			0/+		-1			$Y_{ALG,death}$		$\rho_{death,SALG}$
Het. Bac	Growth het. b. NH4	?	?			-	$\frac{-1}{Y_{HET}}$		1				$\rho_{gro,SHET,NH4}$
	Growth het. b. NO3	?			?	-	$\frac{-1}{Y_{HET}}$		1				$\rho_{gro,SHET,NO3}$
	Resp. of het. bact.	+	+			-			-1				$\rho_{resp,SHET}$
	Death of het. bact.	0/+	0/+			0/+			-1		$Y_{HET,death}$		$\rho_{death,SHET}$
N1	Growth of N1	-	$\frac{-1}{Y_{N1}}$	+		-				1			$\rho_{gro,SN1}$
	Resp. of N1	+	+			-				-1			$\rho_{resp,SN1}$
	Death of N1	0/+	0/+			0/+				-1	$Y_{N1,death}$		$\rho_{death,SN1}$
N2	Growth of N2	-		$\frac{-1}{Y_{N2}}$	+	-					1		$\rho_{gro,SN2}$
	Resp. of N2	+	+			-					-1		$\rho_{resp,SN2}$
	Death of N2	0/+	0/+			0/+					-1	$Y_{N2,death}$	$\rho_{death,SN2}$
	Hydrolysis	0/+	0/+			0/+	$Y_{hyd}$					-1	$\rho_{hyd}$

1. Introduction, principles of modelling environmental systems, mass balance in a mixed reactor, process table notation, simple lake plankton model  
Exercise: R, ecosim-package, simple lake plankton model  
Exercise: lake phytoplankton-zooplankton model
2. Process stoichiometry Exercises: analytical solution, calculation with stoichcalc
3. Biological processes in lakes
4. Physical processes in lakes, mass balance in multi-box and continuous systems Exercise: structured, biogeochemical-ecological lake model  
Assignments: build your own model by implementing model extensions
5. Physical processes in rivers, bacterial growth, river model for benthic populations Exercise: river model for benthic populations, nutrients and oxygen
6. Stochasticity, uncertainty, Parameter estimation  
Exercise: uncertainty, stochasticity
7. Existing models and applications in research and practice, examples and case studies, preparation of the oral exam, feedback

Oral exams will take place between **Thursday 4.6.** and on **Wednesday 10.6.** at Eawag in Dübendorf (exact dates to be discussed today).

It is your responsibility to register/deregister in time.

During the semester you will develop and implement your own model (in teams of two people), interpret simulation results and perform a sensitivity analysis. We will assign topics today.

**Deadline for initial code submission: 07.05.26**

Send your code to **chuxinyao.wang@eawag.ch** and **vloganathan@student.ethz.ch**

**Deadline for submission of R-files, results and interpretation: 22.05.25**

This is mandatory for being admitted to the exam!

In the oral exam we will start with questions about your model before moving on to other topics.

Please use the time in the exercises to ask questions and get help!  
Don't do it last minute.

- Read Chapters 11.5 and 11.6 about the river model
- Think about your questions